

## TECHNICAL DATA SHEET

PRODUCT	<b>HYDROSTATIC TEST EQUIPMENT</b>
MODEL	<b>10-454 REX</b>
SERIES	<b>SERIE 10-REX</b>
API	<b>CERTIFICATED ACCORDING TO THE API</b>



Air operated liquid system, lightweight portable, economic, safety, durable and easy to operate. Made in USA with highest quality components for low operational cost. Available for use on a wide range of fluids including water, oil/ hydraulic and other solubles, requires 80-100 psi air drive pressure to operate. **Designed for Hydrostatic, Burst, Booster, Hydro, Injection, Leak Detector, Pressure Calibration and More.**

10-REX Series are used in most industries including Oil & Gas for: Pressure on Pipes, Valves, Hoses, Vessels, Spools, etc.

### FEATURES/BENEFITS

- Designed for easy maintenance
- Low cost servicing
- Air operated liquids pump
- All pressure valves, tubing, fittings & hardware are stainless 316
- Pressure Chart Recorder Port (Optional)
- Steel frame, Unit weight: 80 pounds - Dimensions: 22"L X 18"H X 14"
- HS Code: 8413.50.0050
- Certificated according to the API
- 24-56 SCFM

### PERFORMANCE DATA

Output Flow	0.20 GPM (0.75 LPM)
Max Output Pressure	45,000 psi (3309)
Air Supply - Driven	100 Psi
Air Inlet Port	1/2" female NPT
Inlet Liquid Port	1/2" female NPT
Outlet Pressure Port	1/4" female FHP
Pump Brand & Ration	SC-Hydraulic Ratio 460:1

## FLOW CURVE RATIO 460:1

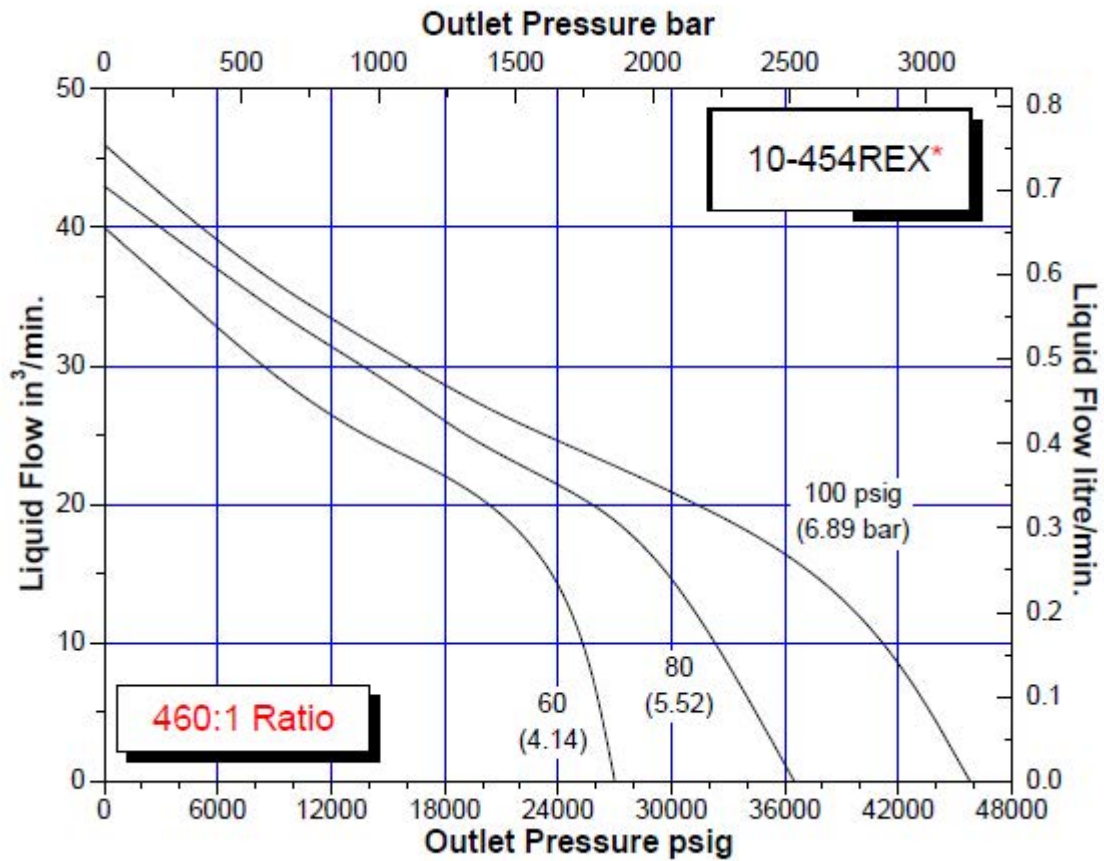

### GENERAL PRODUCT INFORMATION

- When operating from 0 to rated hydraulic pressure, air consumption will be approximately **24-56 scfm** of free air at 100 psi output. At lower air pressures and higher hydraulic pressures air consumption will be reduced proportionately to flow rates indicated.
- The 10REX Series "Dry Lube" pump does not require an air line lubricator.
- Contact Hydrorex for pressure gauges calibration / certificate.
- Maintenance parts for future repairs, all components & accessories can be found on our website [www.hydrorex.com](http://www.hydrorex.com)

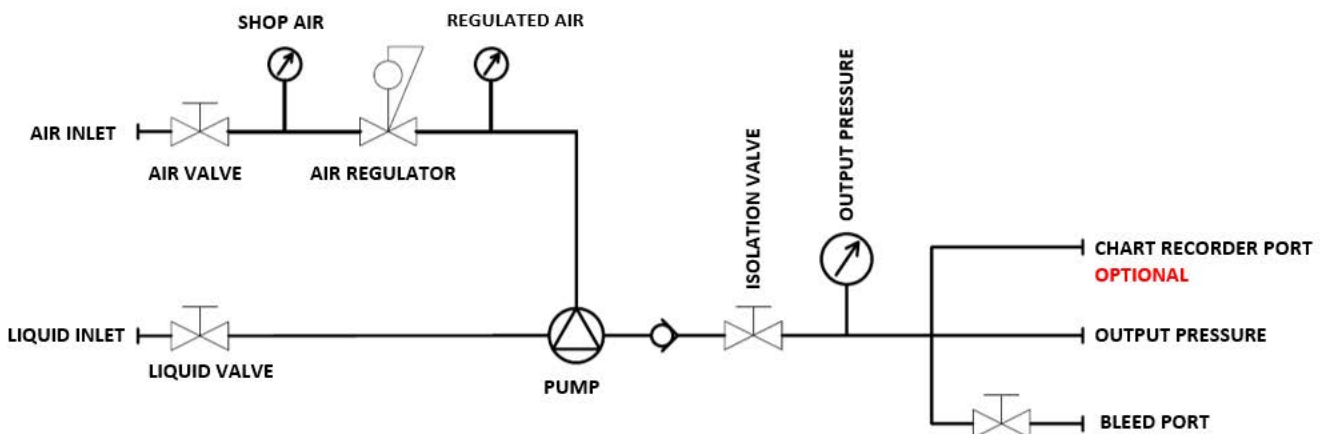

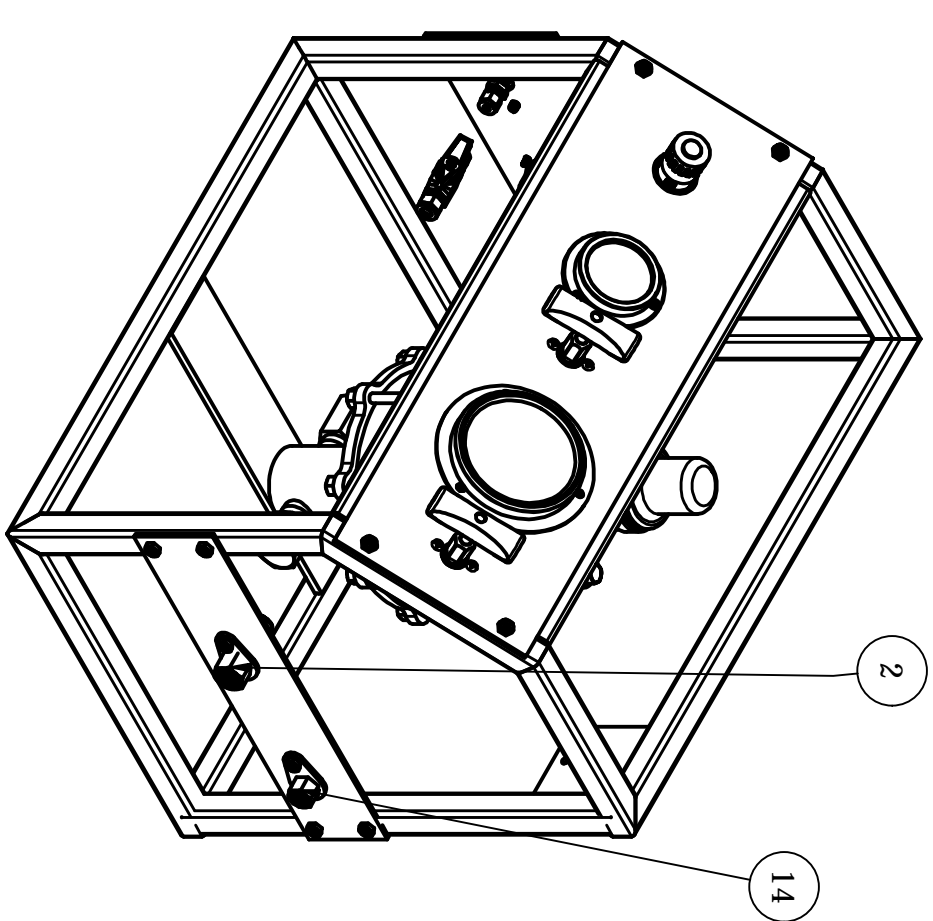
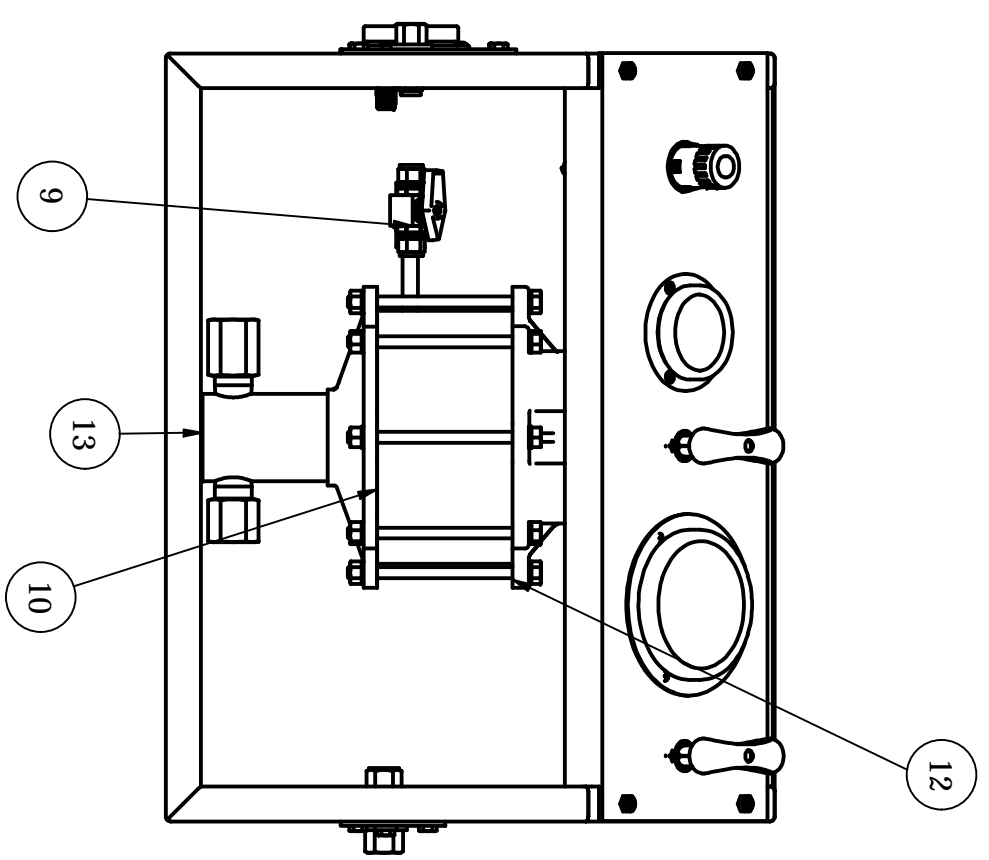
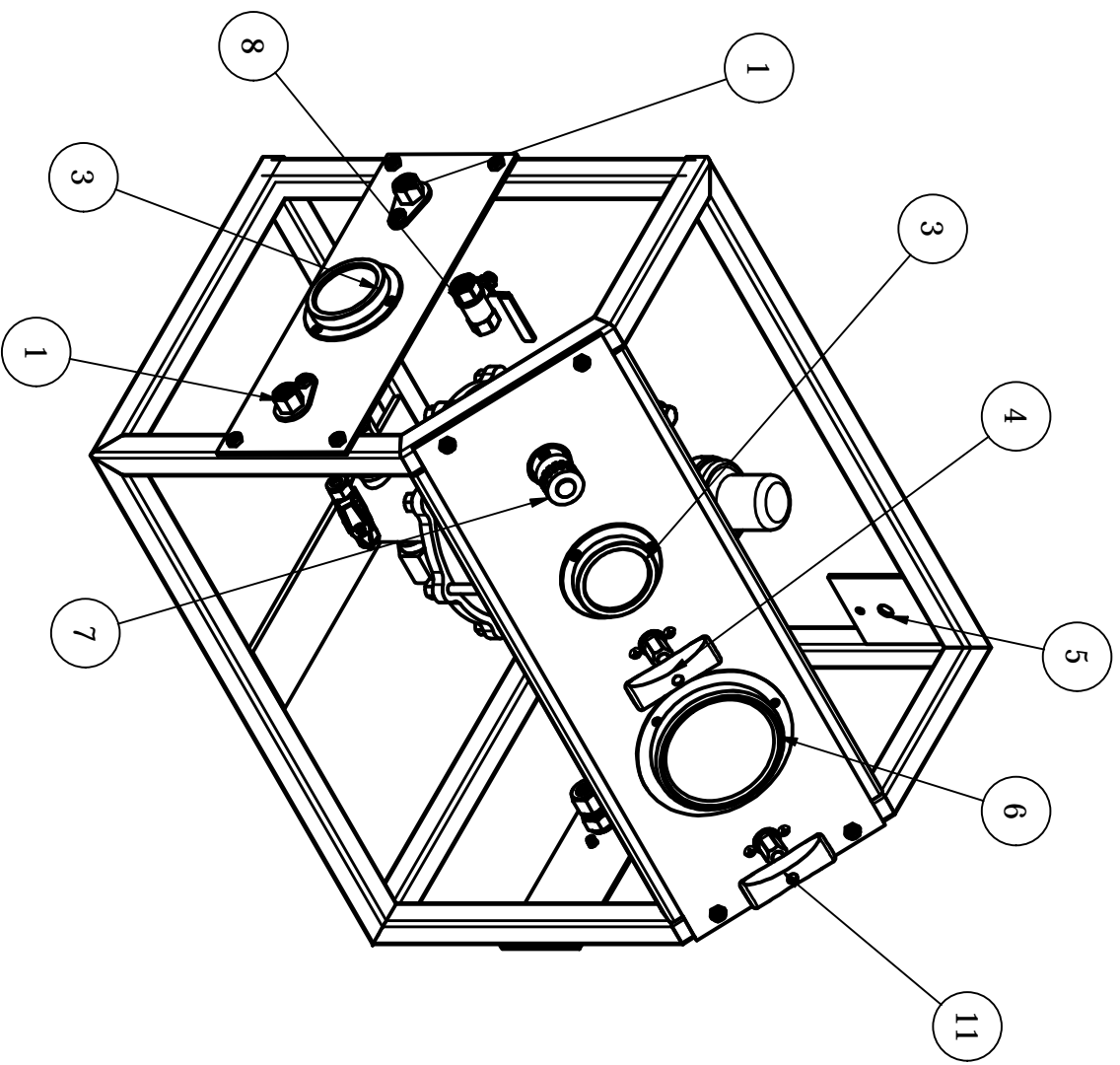

TITLE	SERIES 10-REX			MATERIAL
DRAWN BY	OSCAR GUTIERREZ	APPROVED BY	ELIAS GUTIERREZ	



SCALE	UNITS	SHEET
1 / 6	IN	1

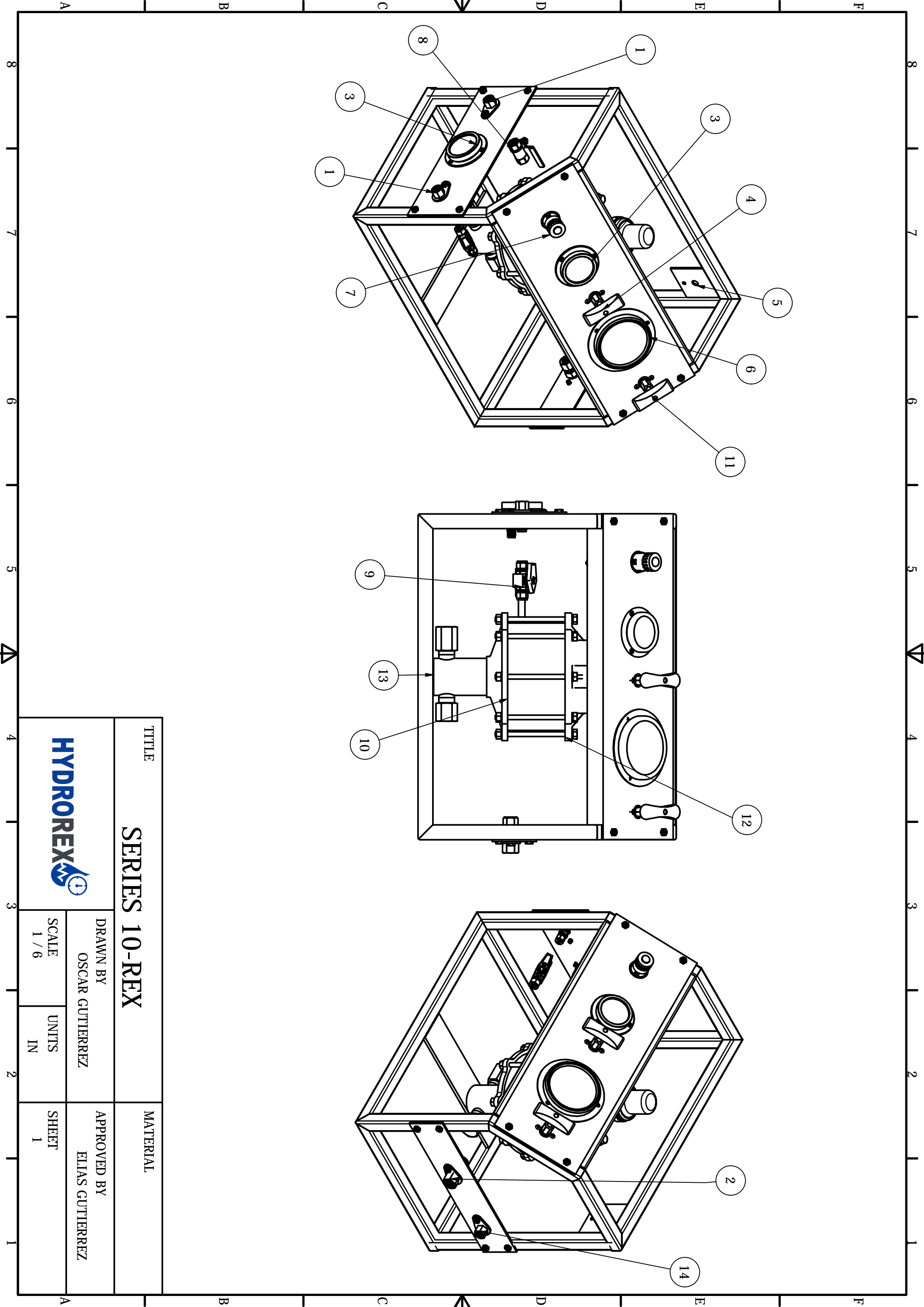

PORT SIZES		DESCRIPTION
TIP	SIZE	DESCRIPTION
1	1/2" FNPT	LIQUID INLET
2	1/2" FNPT	AIR INLET
3	1/4" FNPT	OUTPUT PRESSURE
4	1/4" FNPT	BLEED PORT
5	1/4" FNPT	MONITORING (OPTIONAL)

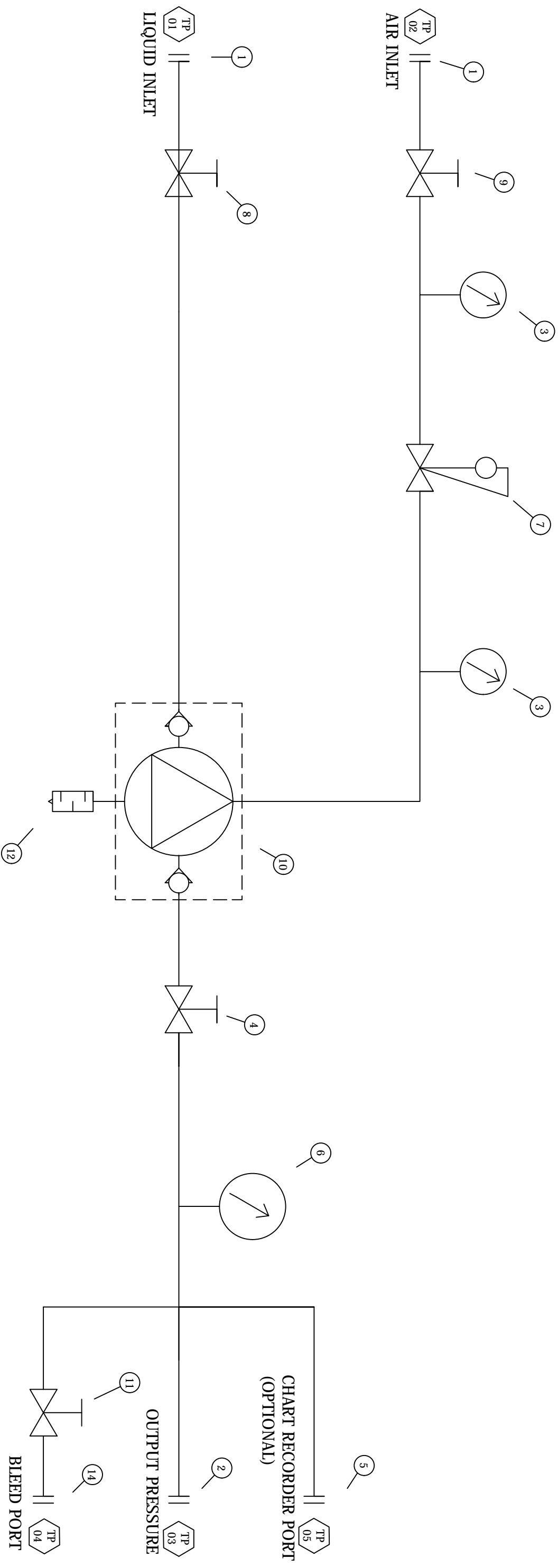

TITLE	10-REX PID		MATERIAL
DRAWN BY	OSCAR GUTIERREZ	APPROVED BY	ELIAS GUTIERREZ



SCALE	1 / 7.5	UNITS	SHEET
			1

INSTRUMENTS AND VALVES

ITEM	QTY	PART NUMBER	DESCRIPTION	10-15IREX	10-18IREX	10-20IREX	10-25IREX	10-306IREX	10-404IREX	10-454IREX	10-552IREX	10-6002IREX
1	3	SS-810-71-8	1/2 FNPT X 1/2 TUBING BULKHEADS	X	X	X	X	X	X	X	X	X
2	1	HC-MF6-BH	3/8 FMP (9/16-18 UNF) Autoclave Bulkhead	X	X	X						
2	1	HC-HF4-BH	1/4 FHP (9/16-18 UNF) Autoclave Bulkhead				X	X	X	X	X	X
3	2	SS-2.5-FLB-160	AIR PRESSURE GUAGES 160 PSI	X	X	X	X	X	X	X	X	X
4	1	SS-NVMF6-20K	3/8 MP NEEDLE VALVE 20K SPIR STAR	X	X	X						
4	1	SS-NVHF4-60K	1/4 HP NEEDLE VALVE 60K SPIR STAR				X	X	X	X	X	X
5	1	HC-HF4-BH	1/4 FHP (9/16-18 UNF) Autoclave Bulkhead	X	X	X	X	X	X	X	X	X
6	1	SS-4-FLB-15K	PRESSURE GAUGE 0-15000 PSI 1/4 FHP	X								
6	1	SS-4-FLB-20K	PRESSURE GAUGE 0-20000 PSI 1/4 FHP		X	X						
6	1	SS-4-FLB-25K	PRESSURE GAUGE 0-25000 PSI 1/4 FHP				X					
6	1	SS-4-FLB-30K	PRESSURE GAUGE 0-30000 PSI 1/4 FHP					X				
6	1	SS-4-FLB-40K	PRESSURE GAUGE 0-40000 PSI 1/4 FHP						X			
6	1	SS-4-FLB-60K	PRESSURE GAUGE 0-600000 PSI 1/4 FHP							X	X	X
7	1	AFR-8	AIR PRESSURE REGULATOR W/FILTER 1/2 FNPT	X	X	X	X	X	X	X	X	X
8	1	SSBV050-2	1/2 FNPT LIQUID BALL VALVE	X	X	X	X	X	X	X	X	X
9	1	SBV120H2-S6	3/8 TUBING BALL VALVE - AIR INLET	X	X	X	X	X	X	X	X	X
10	1	10-6000W080	SC HYDRAULIC LIQUID PUMP	X								
10	1	10-6000W100	SC HYDRAULIC LIQUID PUMP		X							
10	1	10-6000W151	SC HYDRAULIC LIQUID PUMP			X	X					
10	1	10-6000S201-HF4	SC HYDRAULIC LIQUID PUMP					X				
10	1	10-6000S301-HF4	SC HYDRAULIC LIQUID PUMP						X	X		
10	1	10-6000S401-HF4	SC HYDRAULIC LIQUID PUMP								X	
11	1	SS-NVMF4-20K	1/4 NEEDLE VALVE 20K - BLEED PRESSURE	X	X	X						X
11	1	SS-NVHF4-60K	1/4 NEEDLE VALVE 60K - BLEED PRESSURE				X	X	X	X	X	X
12	1	AM-16	1" PUMP AIR MUFFLER	X	X	X	X	X	X	X	X	X
13	2	3/8-24X3/4 BOLTS	PUMP MOUNTING BOLTS 3/8-24X3/4 W/LOCK W.	X	X	X	X	X	X	X	X	X
14	1	SS-400-71-4	1/4 FNPT X TUBING BULKHEAD	X	X	X	X	X	X	X	X	X

TITLE  
**10-REX BOM**

MATERIAL

DRAWN BY  
OSCAR GUTIERREZ

APPROVED BY  
ELIAS GUTIERREZ



SCALE

UNITS

SHEET  
1

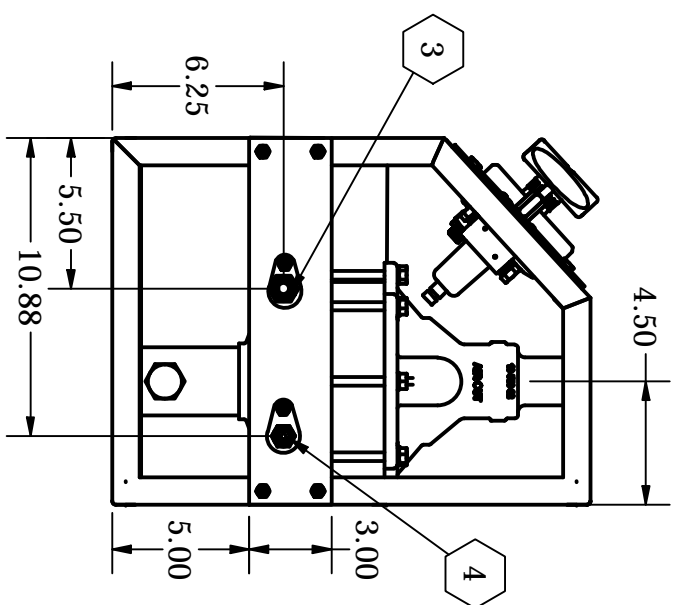
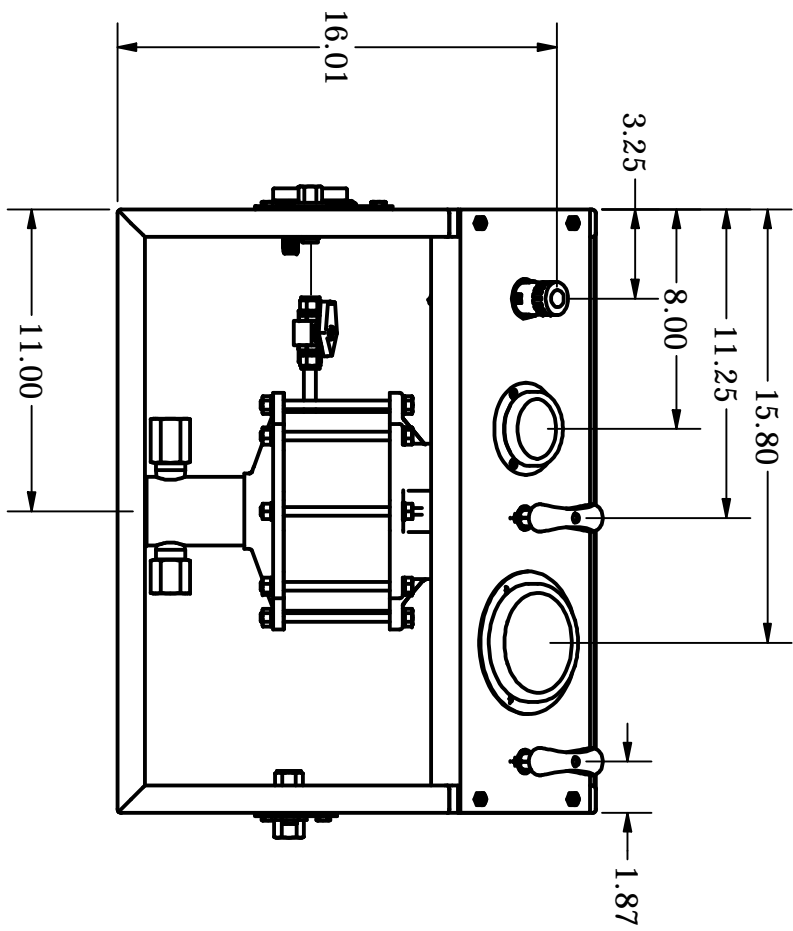
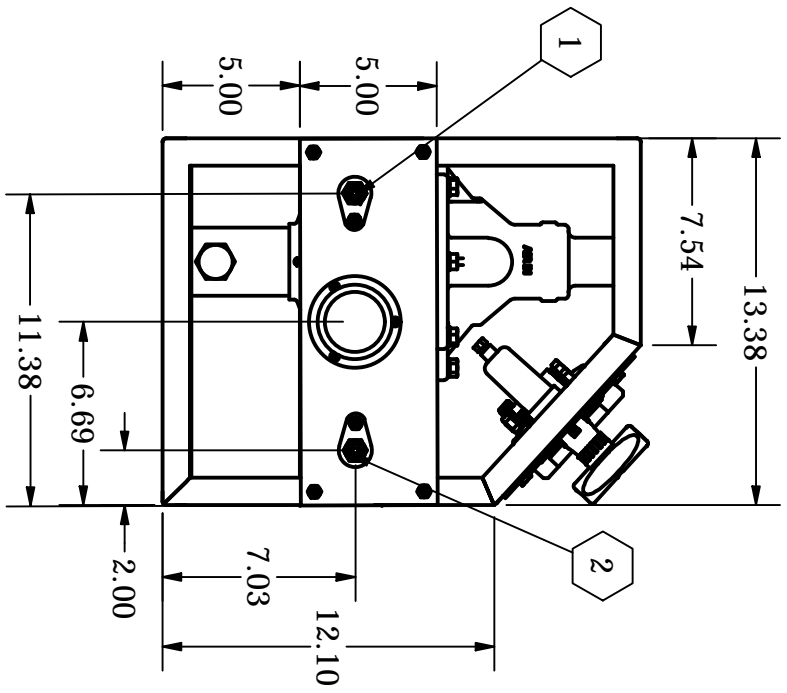
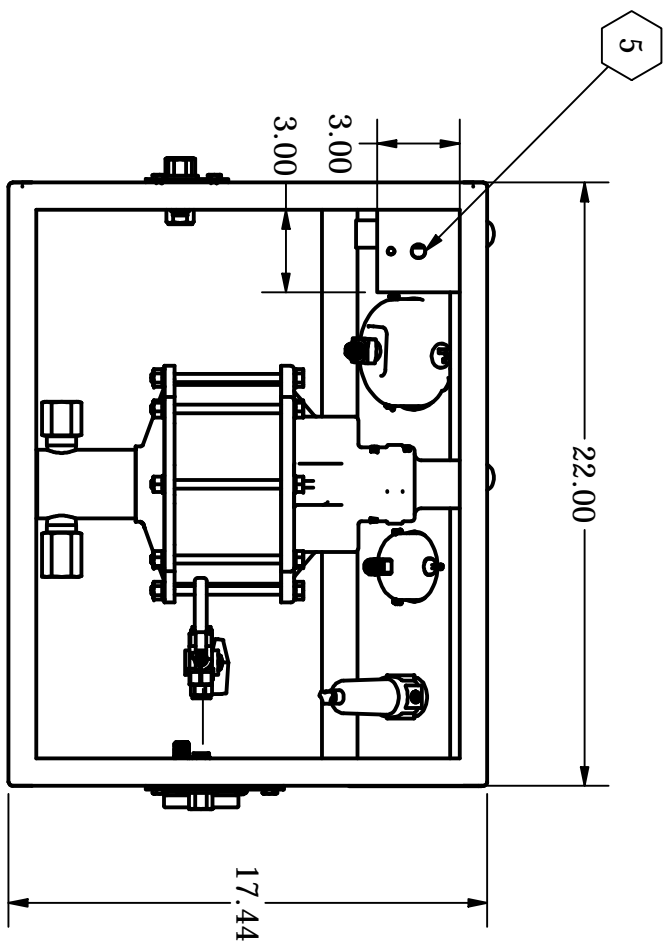
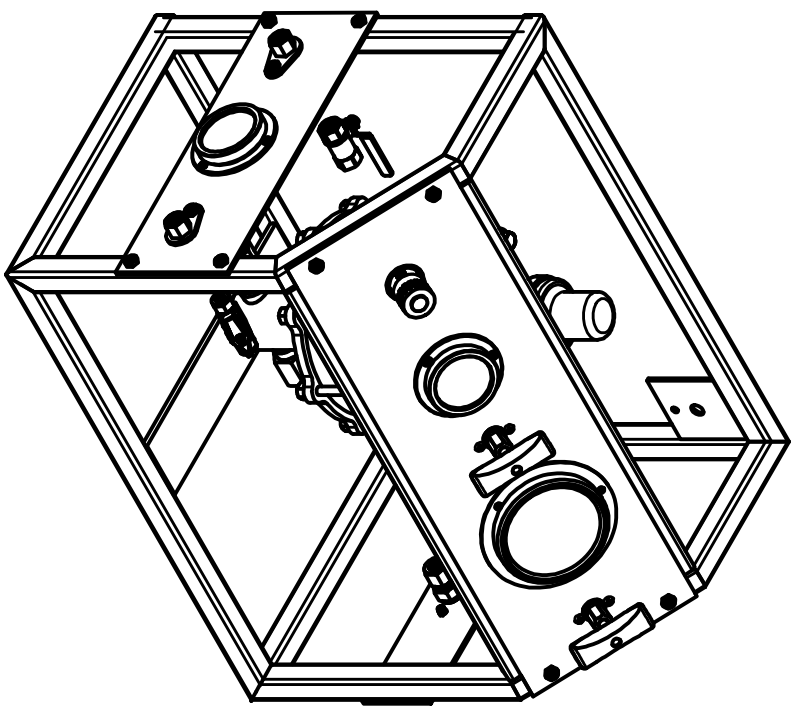

PORT SIZES	
TIP SIZE	DESCRIPTION
1 1/2" FNPT	LIQUID INLET
2 1/2" FNPT	AIR INLET
3 1/4" FNPT	OUTPUT PRESSURE
4 1/4" FNPT	BLEED PORT
5 1/4" FNPT	MONITORING (OPTIONAL)

TITLE: **SERIES 10-REX** MATERIAL:

DRAWN BY: OSCAR GUTIERREZ APPROVED BY: ELIAS GUTIERREZ



SCALE: 1/7 UNITS: IN SHEET: 1

