

TECHNICAL DATA SHEET

PRODUCT	HYDROSTATIC TEST EQUIPMENT
MODEL	10-102 REX
SERIES	SERIE 10-REX
API	CERTIFIED ACCORDING TO API SPECIFICATIONS



Air operated liquid system that is lightweight portable, economic, safe, durable and easy to operate. Made in USA with highest quality components for low operational cost. Available for use on a wide range of fluids including water, oil/hydraulic and other solubles; requires 80-100 psi air drive pressure to operate. **Designed for Hydrostatic, Burst, Booster, Hydro, Injection, Leak Detector, Pressure Calibration and More.**

10-REX Series are used in most industries including Oil & Gas for: Pressure on Pipes, Valves, Hoses, Vessels, Spools, etc.

FEATURES/BENEFITS

- Designed for easy maintenance
- Low cost servicing
- Air operated liquid pumps
- All pressure valves, tubing, fittings & hardware are stainless 316
- Pressure Chart Recorder Port (Optional)
- Steel frame, Unit weight: 80 pounds - Dimensions: 22"L X 14" W 18"H
- HS Code: 8413.50.0050
- Certificated according to API specifications
- 24-56 SCFM

PERFORMANCE DATA

Output Flow	1.05 GPM (4.0 LPM)
Max Output Pressure	10000 psi (685 bar)
Air Supply - Driven	100 Psi
Air Inlet Port	1/2" female NPT
Inlet Liquid Port	1/2" female NPT
Outlet Pressure Port	1/4" female NPT
Pump Brand & Ration	SC-Hydraulic Ratio 95:1

FLOW CURVE RATIO 95:1

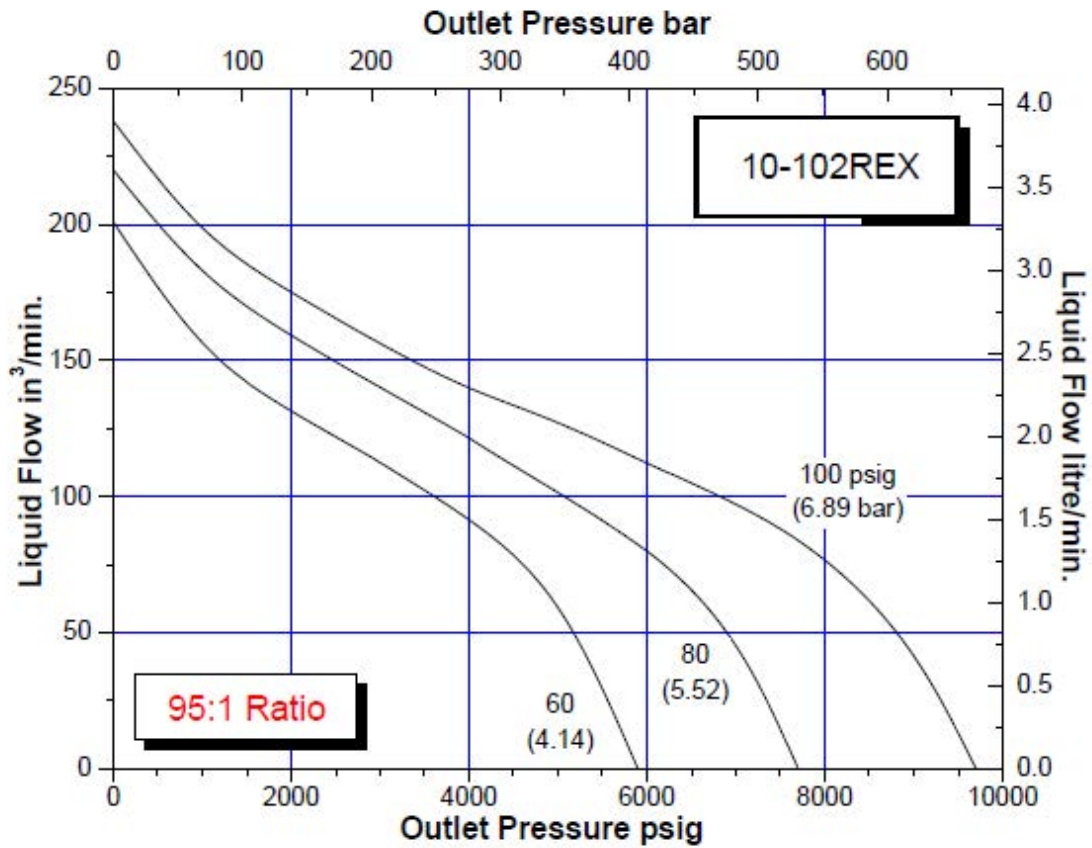

GENERAL PRODUCT INFORMATION

- When operating from 0 to rated hydraulic pressure, air consumption will be approximately **24-56 scfm** of free air at 100 psi output. At lower air pressures and higher hydraulic pressures air consumption will be reduced proportionately to flow rates indicated.
- The 10REX Series "Dry Lube" pump does not require an air line lubricator.
- Contact Hydrorex for pressure gauges calibration / certificate.
- Maintenance parts for future repairs, all components & accessories can be found on our website www.hydrorex.com.

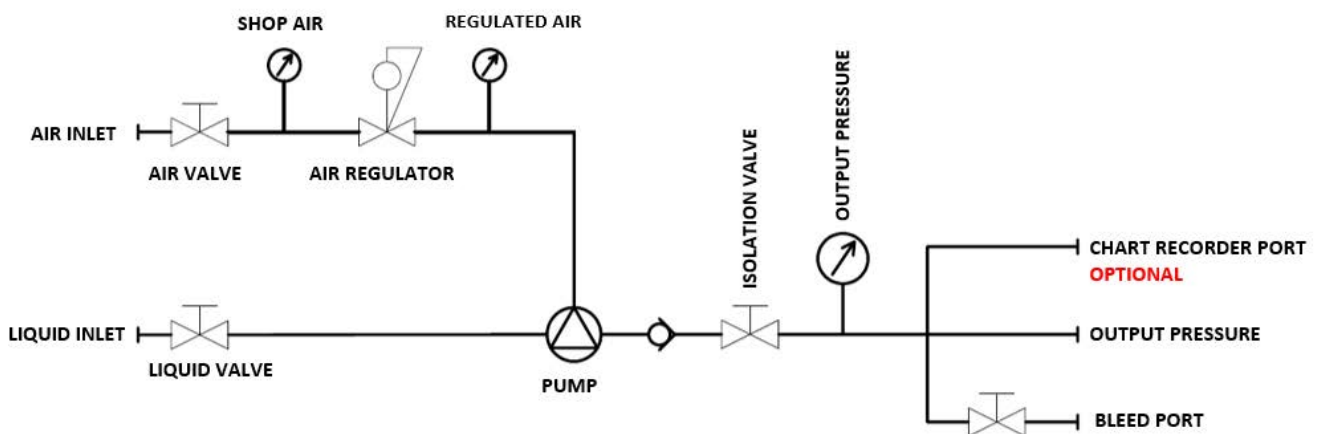

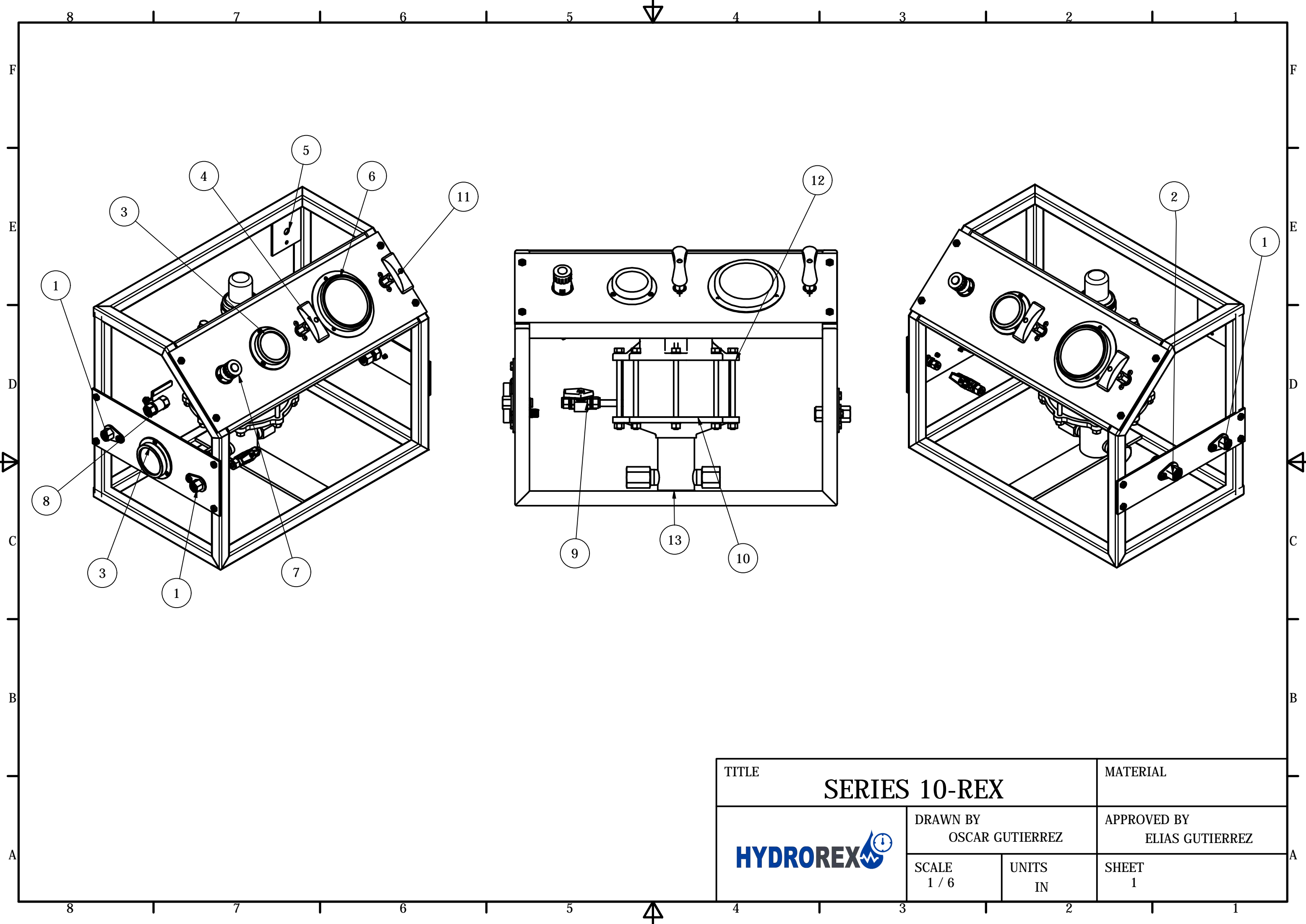

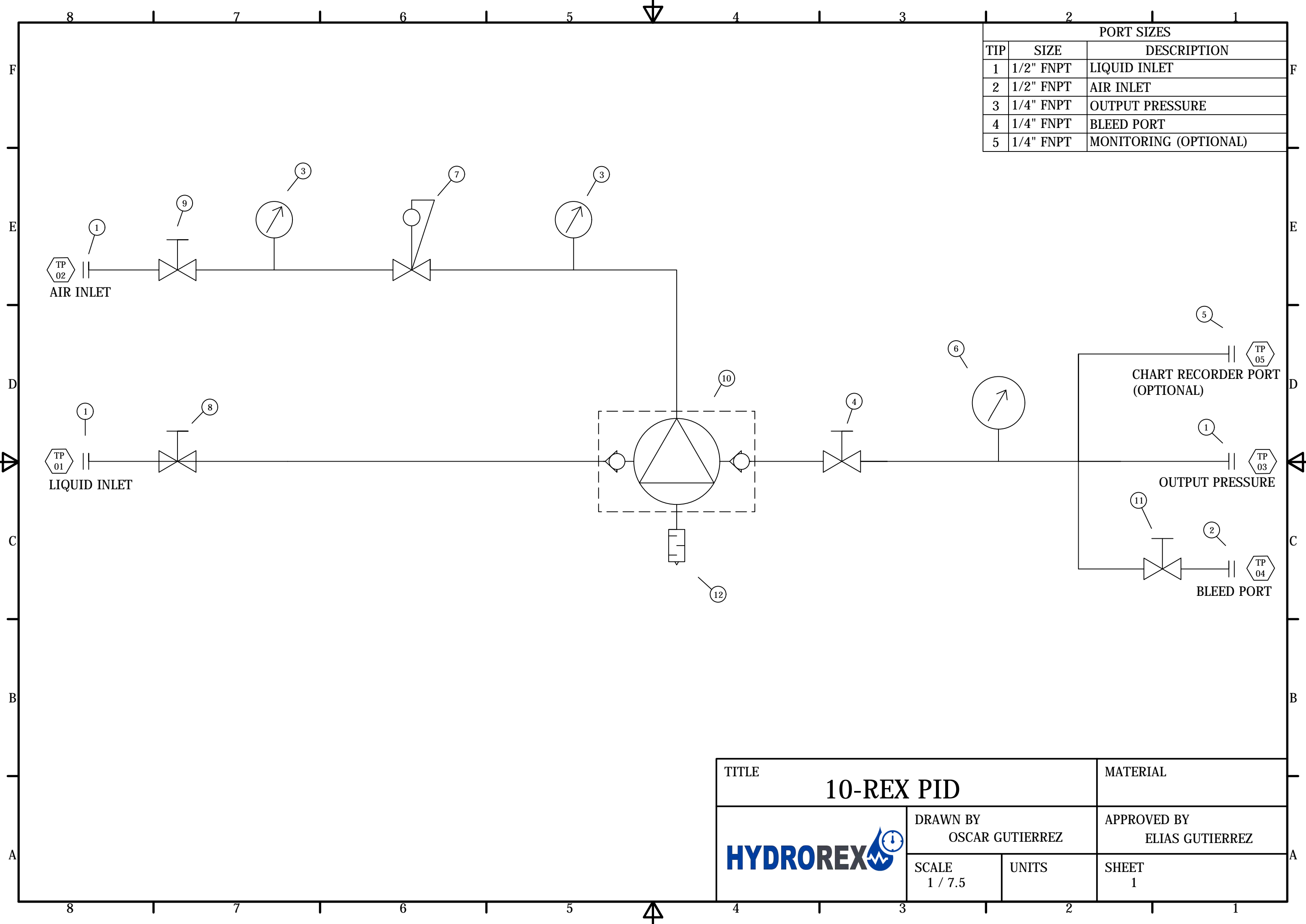

TITLE		SERIES 10-REX		MATERIAL	
		DRAWN BY OSCAR GUTIERREZ		APPROVED BY ELIAS GUTIERREZ	
		SCALE 1 / 6	UNITS IN	SHEET 1	



PORT SIZES		
TIP	SIZE	DESCRIPTION
1	1/2" FNPT	LIQUID INLET
2	1/2" FNPT	AIR INLET
3	1/4" FNPT	OUTPUT PRESSURE
4	1/4" FNPT	BLEED PORT
5	1/4" FNPT	MONITORING (OPTIONAL)

TITLE		10-REX PID		MATERIAL	
		DRAWN BY		APPROVED BY	
		OSCAR GUTIERREZ		ELIAS GUTIERREZ	
SCALE		UNITS		SHEET	
1 / 7.5				1	

INSTRUMENTS AND VALVES											
ITEM	QTY	PART NUMBER	DESCRIPTION	10-515REX	10-109REX	10-2016REX	10-365REX	10-603REX	10-102REX		
F	1	3	SS-810-71-8	1/2 FNPT X 1/2 TUBING BULKHEADS	X	X	X	X	X	X	F
	2	1	SS-400-71-4	1/4 FNPT X 1/4 TUBING BULKHEAD	X	X	X	X	X	X	
	3	2	SS-2.5-FLB-160	AIR PRESSURE GUAGES 160 PSI	X	X	X	X	X	X	
	4	1	SBV120H4-F8N	1/2 FNPT BALL VALVE 3000 PSI	X	X	X				
	4	1	SBV120H2-S6	3/8 TUBING BALL VALVE 3000 PSI			X				
	4	1	SS-NVNF4-15K	1/4 FNPT NEEDLE VALVE SPIR STAR				X	X	X	
E	5	1	SS-400-71-4	1/4 FNPT X 1/4 TUBING BULKHEAD (OPTIONAL)	X	X	X	X	X	X	E
	6	1	SS-4-FLB-600	PRESSURE GAUGE 0-600 PSI 1/4 MNPT	X						
	6	1	SS-4-FLB-1K	PRESSURE GAUGE 0-1000 PSI 1/4 MNPT		X					
	6	1	SS-4-FLB-2K	PRESSURE GAUGE 0-2000 PSI 1/4 MNPT			X				
	6	1	SS-4-FLB-4K	PRESSURE GAUGE 0-4000 PSI 1/4 MNPT				X			
	6	1	SS-4-FLB-6K	PRESSURE GAUGE 0-6000 PSI 1/4 MNPT					X		
D	6	1	SS-4-FLB-10K	PRESSURE GAUGE 0-10000 PSI 1/4 MNPT						X	D
	7	1	AFR-8	AIR PRESSURE REGULATOR W/FILTER 1/2 FNPT	X	X	X	X	X	X	
	8	1	SSBV050-2	1/2 FNPT LIQUID BALL VALVE	X	X	X	X	X	X	
	9	1	SBV120H2-S6	3/8 TUBING BALL VALVE - AIR INLET	X	X	X	X	X	X	
	10	1	10-5000W003	SC HYDRAULIC LIQUID PUMP	X						
	10	1	10-5000W005	SC HYDRAULIC LIQUID PUMP		X					
	10	1	10-6000W010	SC HYDRAULIC LIQUID PUMP			X				
	10	1	10-6000W020	SC HYDRAULIC LIQUID PUMP				X			
	10	1	10-6000W030	SC HYDRAULIC LIQUID PUMP					X		
	10	1	10-6000W050	SC HYDRAULIC LIQUID PUMP						X	
	11	1	SBV120-H2-S4	1/4 TUBING BALL VALVE - BLEED PRESSURE	X	X	X				
	11	1	SS-NVNF4-15K	1/4 FNPT NEEDLE VALVE SPIRT START				X	X	X	
B	12	1	AM-12	3/4 PUMP AIR MUFFLER	X	X					B
	12	1	AM-16	1" PUMP AIR MUFFLER			X	X	X	X	
	13	2	3/8-24X3/4 BOLTS	PUMP MOUNTING BOLTS 3/8-24X3/4 W/LOCK W.	X	X	X				
				TITLE 10REX BOM				MATERIAL			
						DRAWN BY OSCAR GUTIERREZ		APPROVED BY ELIAS GUTIERREZ			
						SCALE	UNITS	SHEET 1			

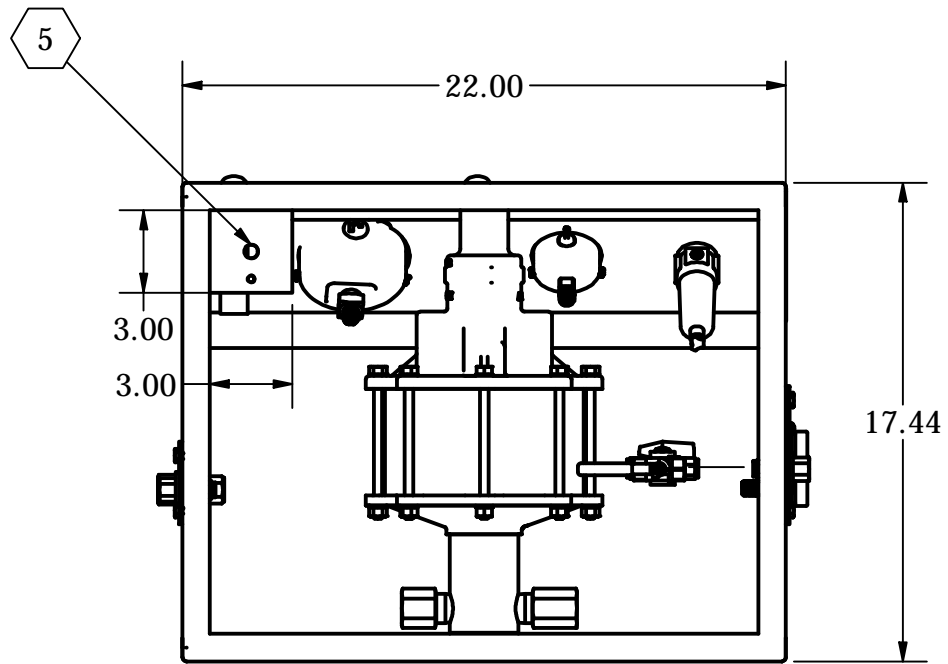
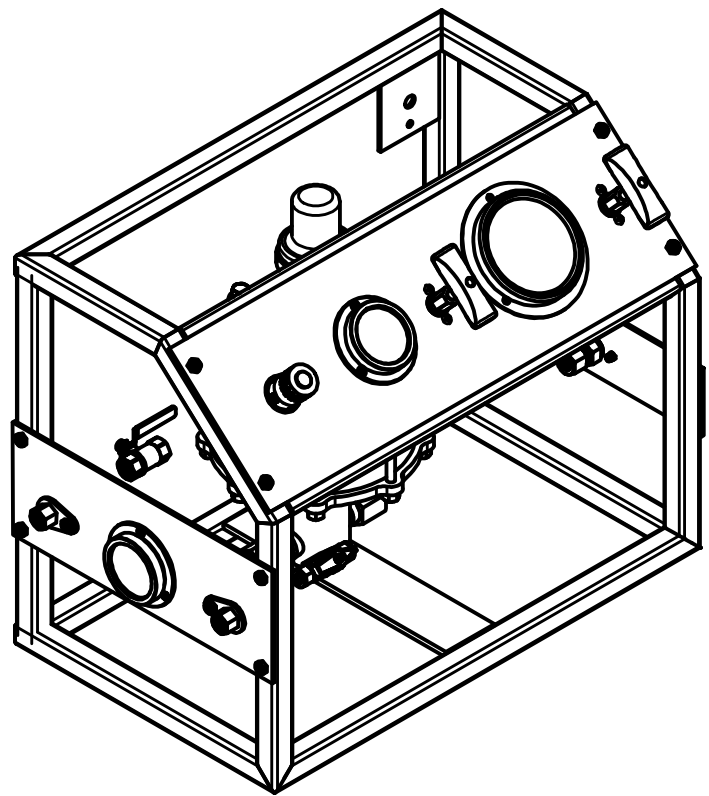

PORT SIZES		
TIP	SIZE	DESCRIPTION
1	1/2" FNPT	LIQUID INLET
2	1/2" FNPT	AIR INLET
3	1/4" FNPT	OUTPUT PRESSURE
4	1/4" FNPT	BLEED PORT
5	1/4" FNPT	MONITORING (OPTIONAL)

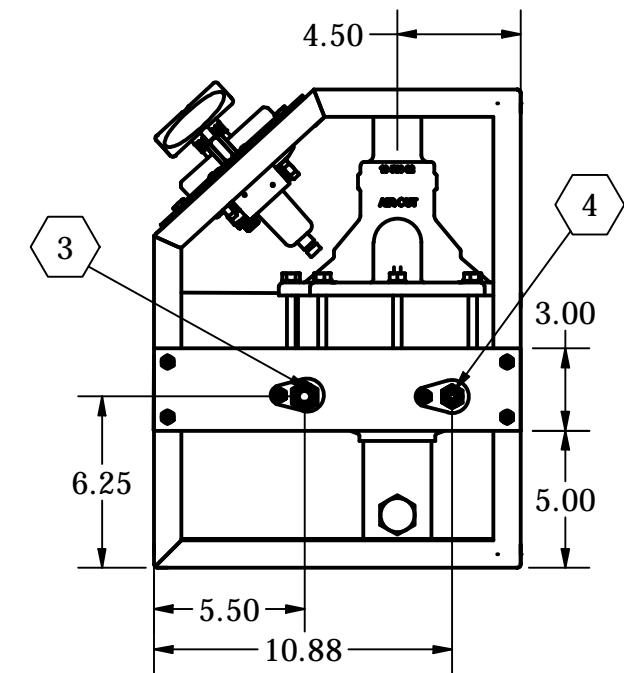
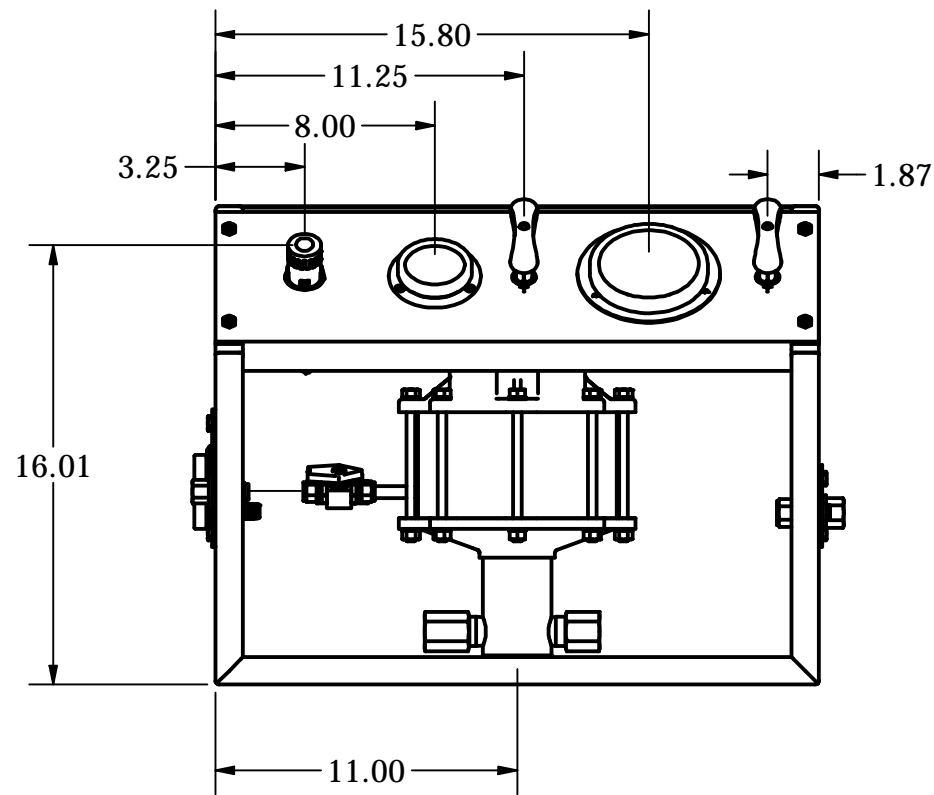
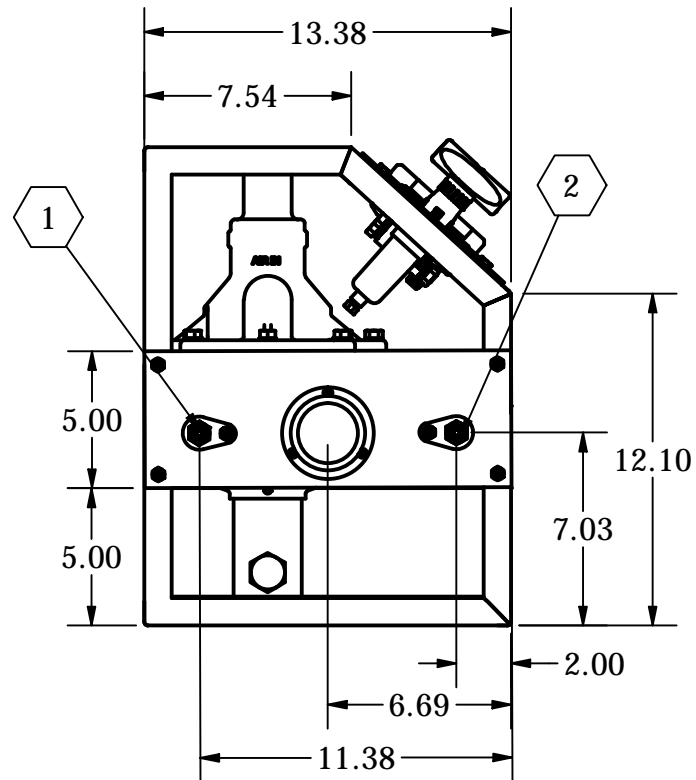

TITLE		SERIES 10-REX		MATERIAL	
		DRAWN BY OSCAR GUTIERREZ		APPROVED BY ELIAS GUTIERREZ	
		SCALE 1 / 7	UNITS IN	SHEET 1	