

SE Hydraulic
Engineering

HYDROREX 



sales@hydrorex.com - eli@hydrorex.com
Office: 832 277 1182

13360 TELGE RD #606 CYPRESS TEXAS 77429 USA

U7 REX SERIES

HYDROSTATIC UNIT

ALL STAINLESS 316

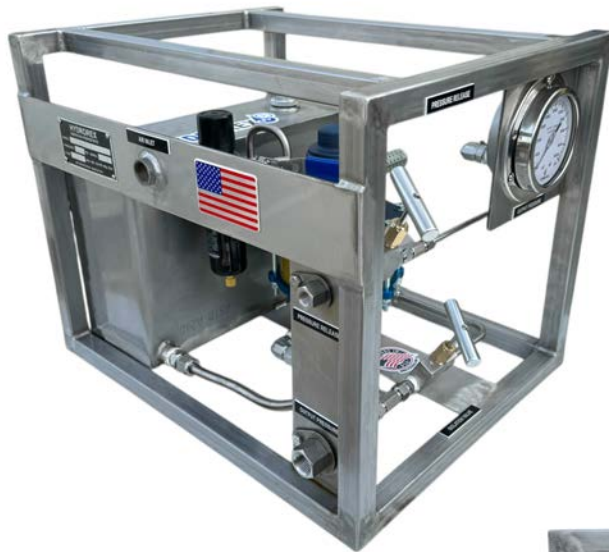

www.hydrorex.com
www.pressureshop.com

P
U
M
P
S

U7-REX Series All Stainless 316

Anticorrosive

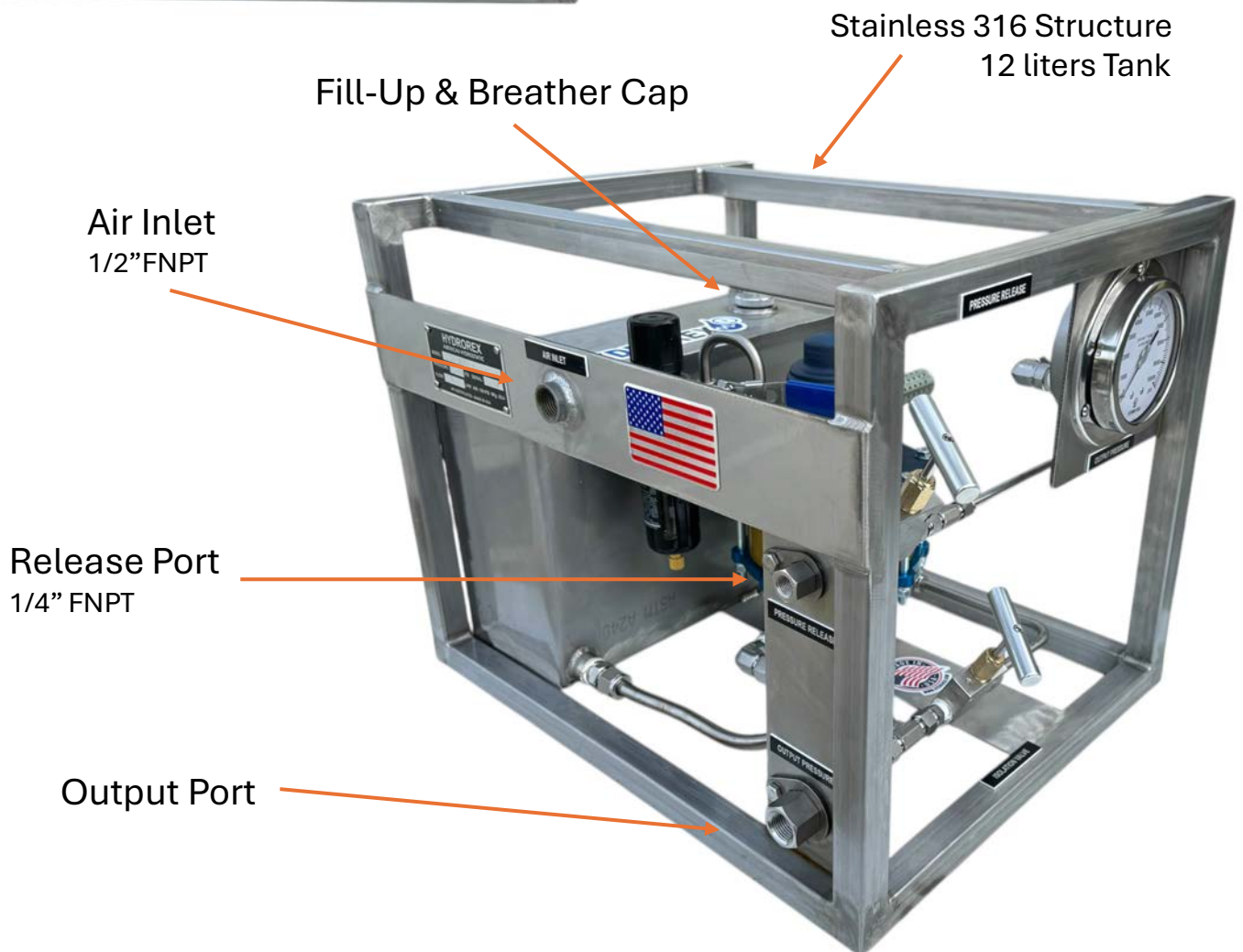
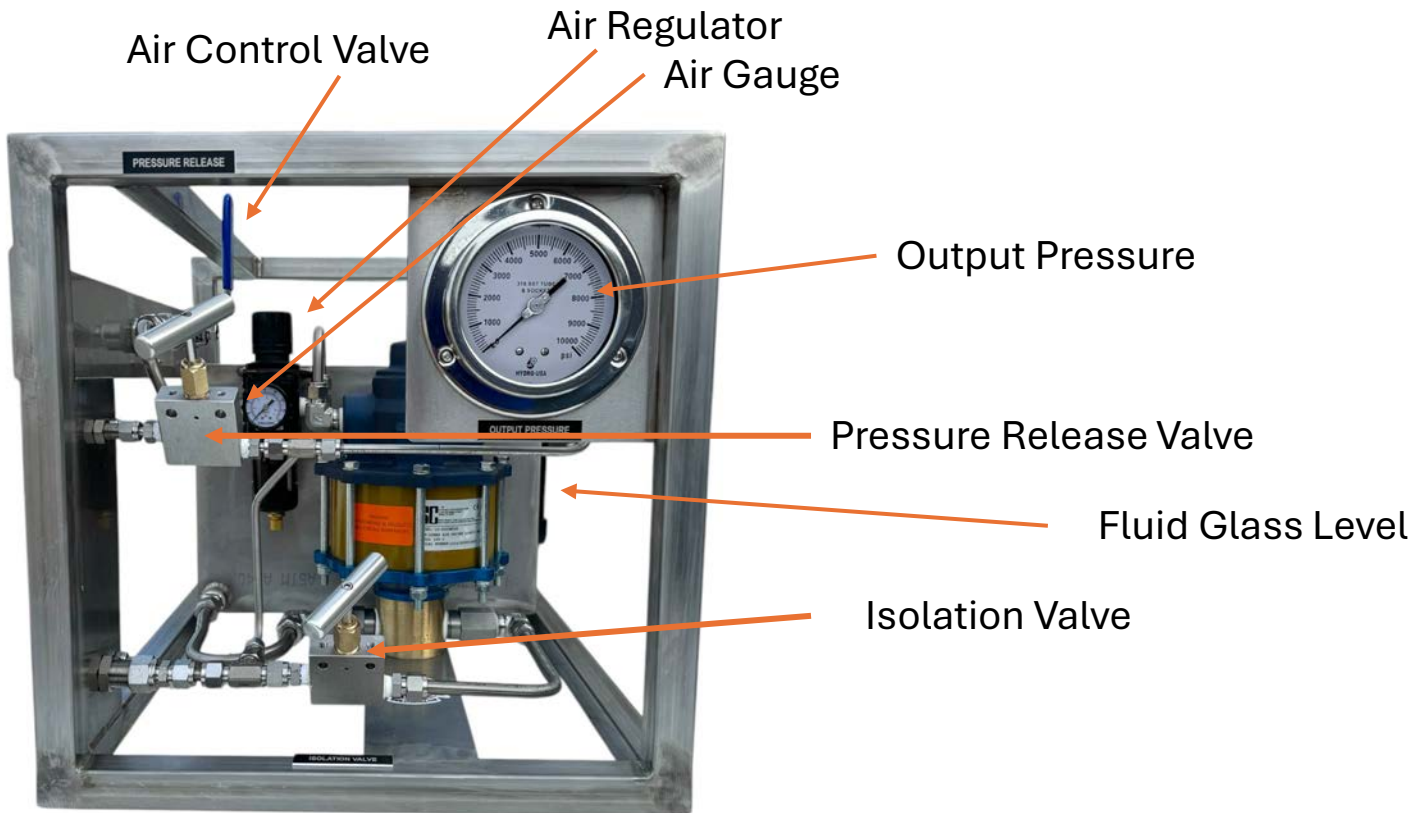

U7 REX SERIES

"The Compact & Complete Unit" All stainless steel with liquid reservoir tank, lightweight, portable and easy to operate. Anticorrosive.

LOW, MEDIUM & HIGH PRESSURE: Is a pneumatic drive system, 14 models are available with pressures up to 56,000 psig. ideal for testing in small confined spaces and remote locations. Designed for liquids pressure on all industries including Oil & Gas for use with any liquid such water, glycol, hydraulic, oils and more.

Made in USA with highest quality components for low operational cost.

When operating from 0 to rated hydraulic pressure, air consumption will be approximately 18-28 scfm of free air at 100 psi output. At lower air pressures and higher hydraulic pressures air consumption will be reduced proportionately to flow rates indicated.

The U7-REX Series "Dry Lube" pump does not require an air line lubricator

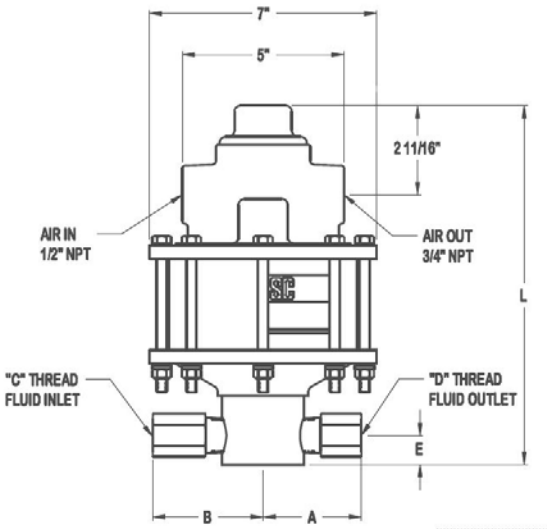

For pressure, flow rates and ports size for each model, please download the model datasheet below the product on the web www.hydrorex.com

Components: USA Brands, Parker, HYDRO-USA, SC Hydraulic, Swagelok

- Structure: Heavy duty 1" tubing 316 stainless steel
- All Stainless steel, valves, tubing, fittings & hardware
- Stainless 12 Liters liquid tank (3 Gallons)
- Requires 60 – 100 psi air pressure to operate (18-28 SCFM)

Dimensions: 20" Length, 16" High, 16" Width
Weight: 55 Lbs
Shipping Dimensions: L"24 x 18" H x 18" W
Shipping Weight: 65 Lbs
HS Code: 8413.50.0050



*Coned and Threaded High Pressure Connection for 1/4" O.D. Tubing

Measurements & Approximate Air to Hydraulic Pressure Ratios – Static Conditions

Pressure Ratio	U7-REX Series Model	Hydraulic Piston Diameter (in)	Hydraulic Piston Area (in ²)	Volume per Stroke (in ³)	Air Pressure (PSI)									
					10	20	30	40	50	60	70	80	90	100
5	U7-515REX	2.3750	4.430	5.540	30	75	130	175	220	270	320	370	415	465
10	U7-109REX	1.6250	2.070	2.590	80	180	285	385	490	590	690	795	900	1000
20	U7-186REX	1.1875	1.110	1.390	145	330	525	700	925	1100	1300	1500	1700	1900
25	U7-264REX	1.0000	0.785	0.981	200	475	750	1000	1300	1550	1800	2000	2350	2625
30	U7-323REX	0.9375	0.689	0.861	225	525	875	1150	1500	1775	2050	2350	2700	3075
35	U7-363REX	0.8750	0.601	0.751	250	600	1000	1400	1775	2125	2475	2825	3200	3625
55	U7-602REX	0.6875	0.371	0.464	400	1000	1700	2200	2900	3400	4000	4600	5200	5800
70	U7-701REX	0.6250	0.307	0.384	500	1175	1950	2600	3350	4100	4900	5600	6350	7000
85	U7-901REX	0.5625	0.248	0.310	800	1700	2600	3400	4400	5100	6000	6900	7800	8600
105	U7-119REX	0.5000	0.196	0.245	900	2000	3150	4200	5400	6400	7450	8500	9700	10700
140	U7-148REX	0.4375	0.150	0.188	1100	2400	3900	5400	6900	8300	9800	11200	12600	14000
195	U7-206REX	0.3750	0.110	0.138	1400	3250	5250	7250	9250	11250	13250	15000	17000	19750
280	U7-284REX	0.3125	0.077	0.096	2250	4000	7750	10500	13500	16250	18750	21500	24500	27500
440**	U7-402REX	0.2500	0.049	0.061	5000	8000	12500	16500	21000	25500	30000	34000	38000	40000
555**	U7-562REX	0.2000	0.042	0.051	6000	10000	14500	19500	26000	29500	36000	40000	48000	56000

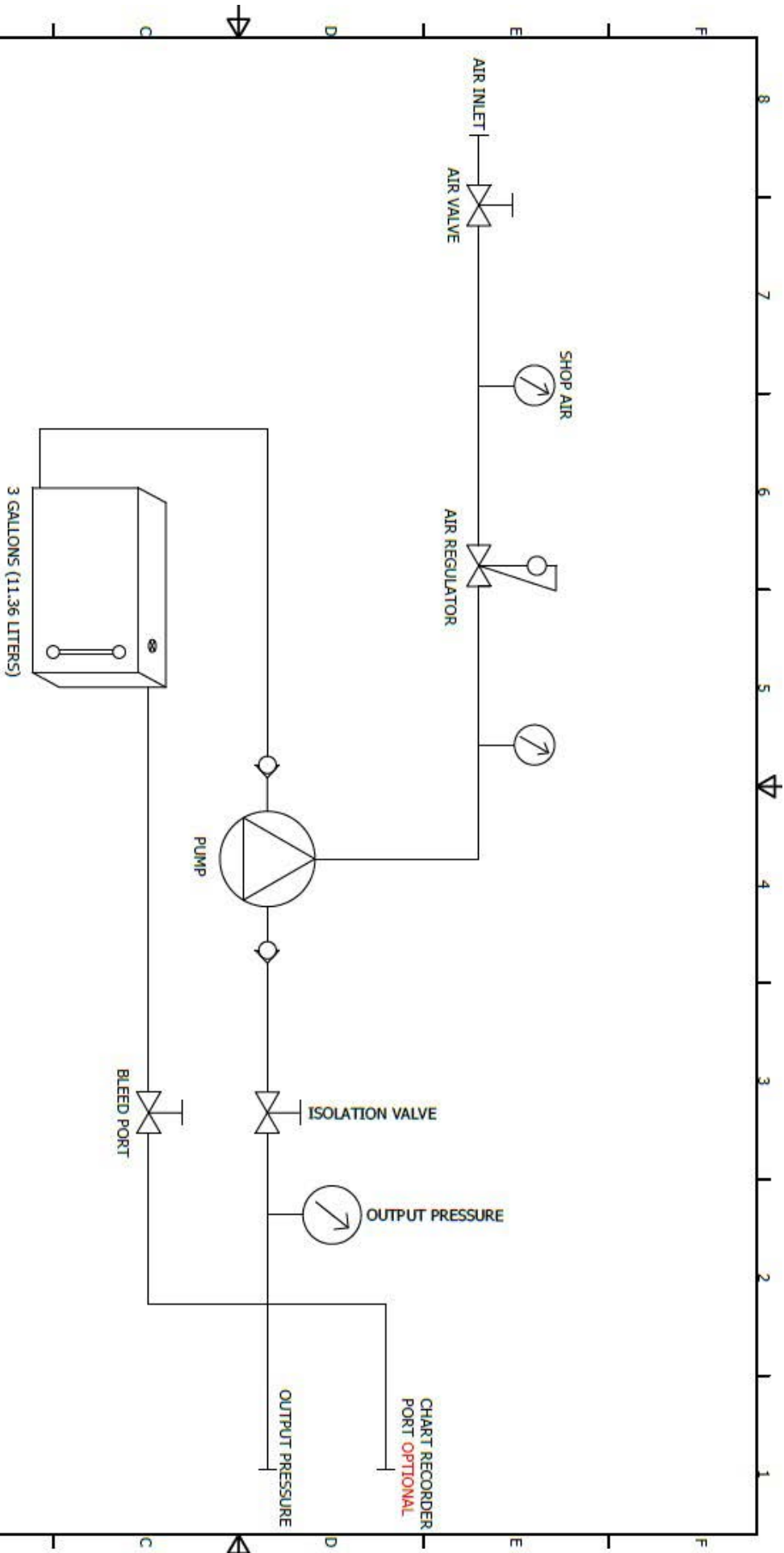

TITLE		U7-REX		MATERIAL		STAINLESS STEEL	
DRAWN BY		OSCAR GUTIERREZ		APPROVED BY		ELIAS GUTIERREZ	
SCALE		1/8"		UNITS		IN	
HYDROREX		SHEET		1			

8 7 6 5 4 3 2 1

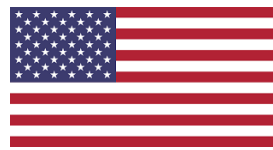

U7 REX SERIES

APPROXIMATE RATE OF DISCHARGE

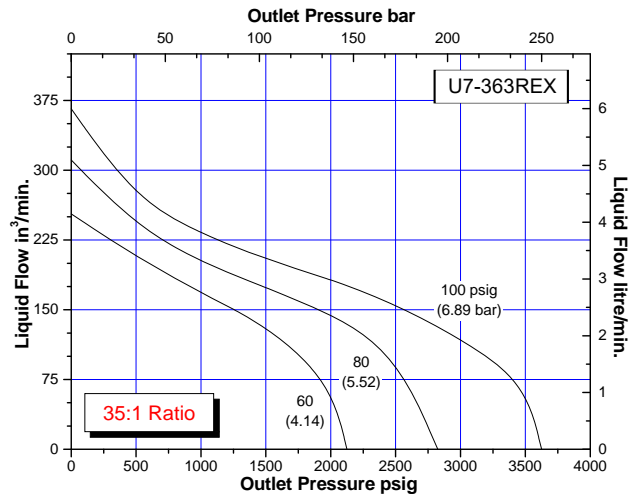
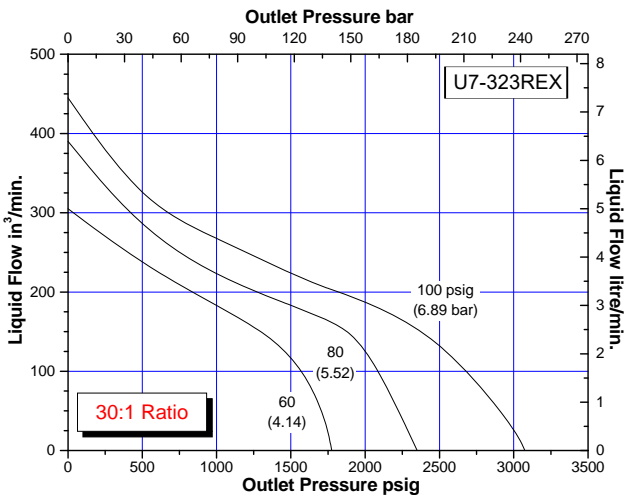
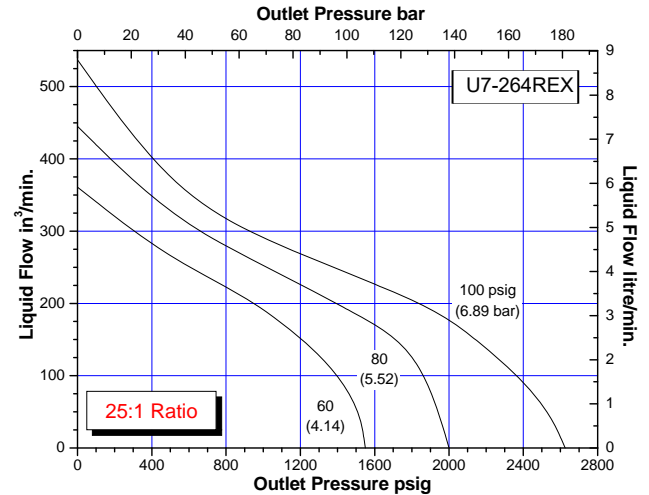
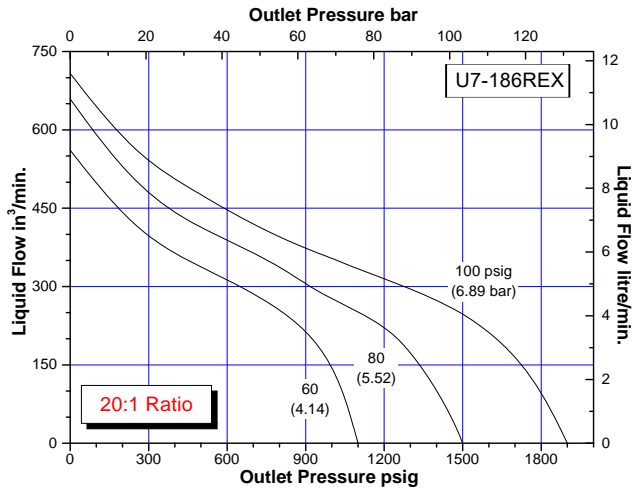
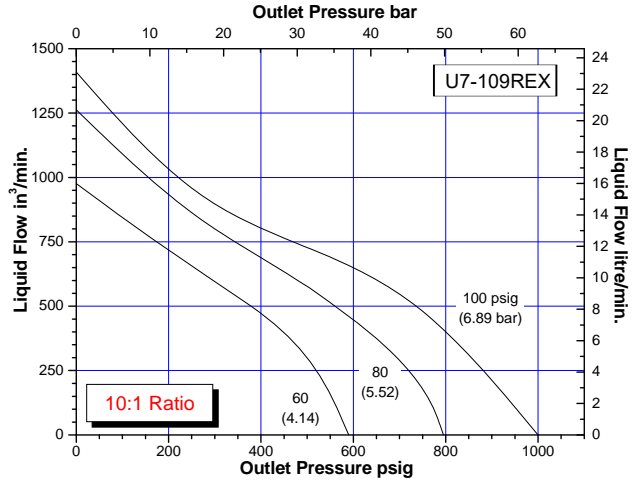
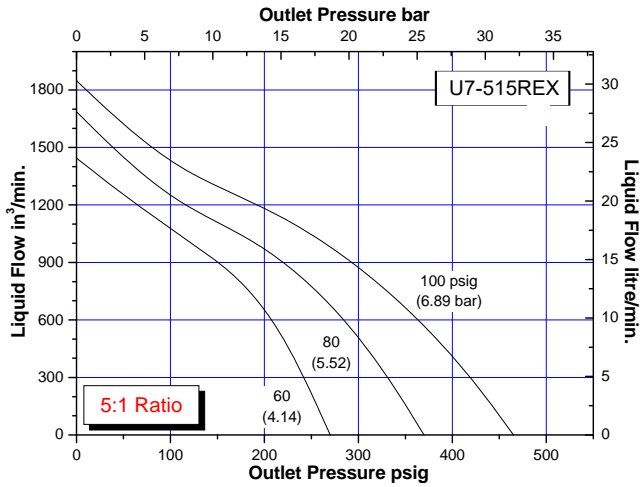

U7 REX SERIES

APPROXIMATE RATE OF DISCHARGE

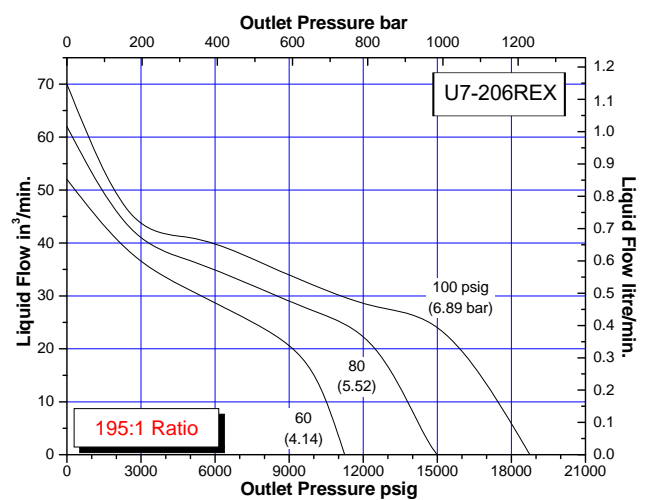
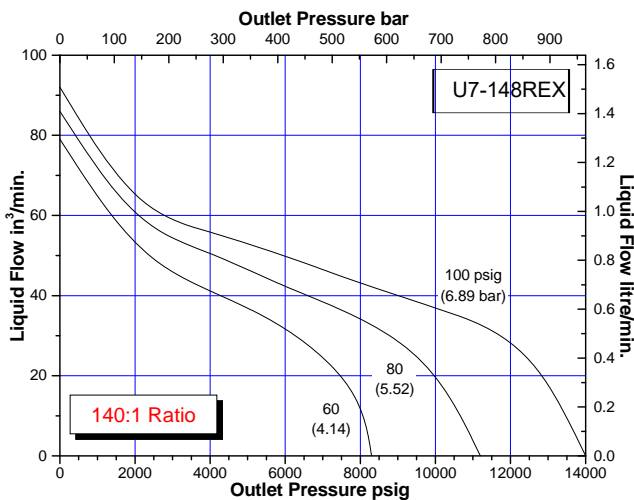
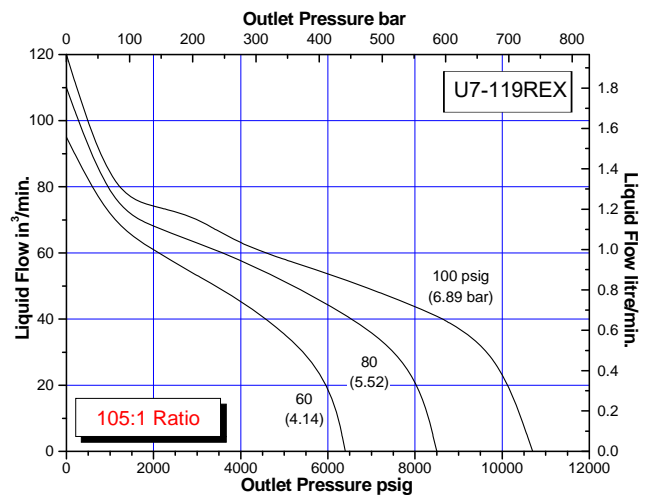
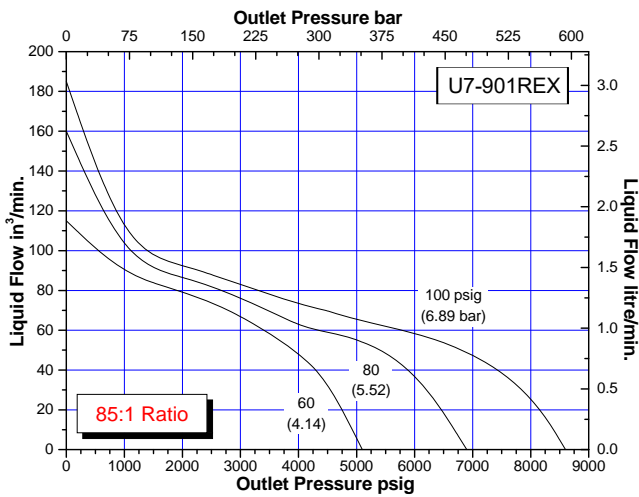
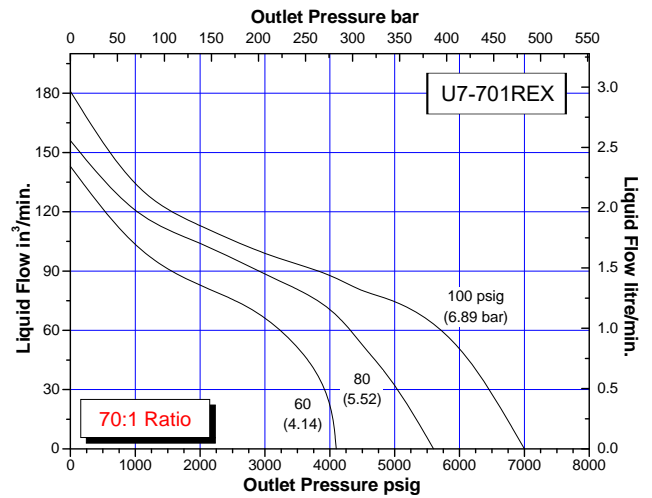
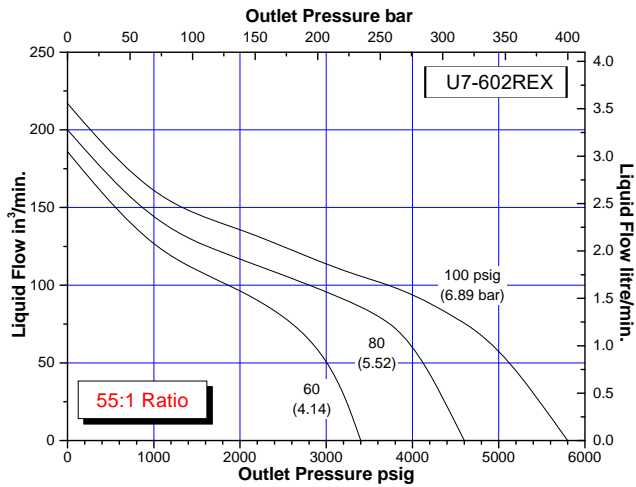

U7 REX SERIES

APPROXIMATE RATE OF DISCHARGE

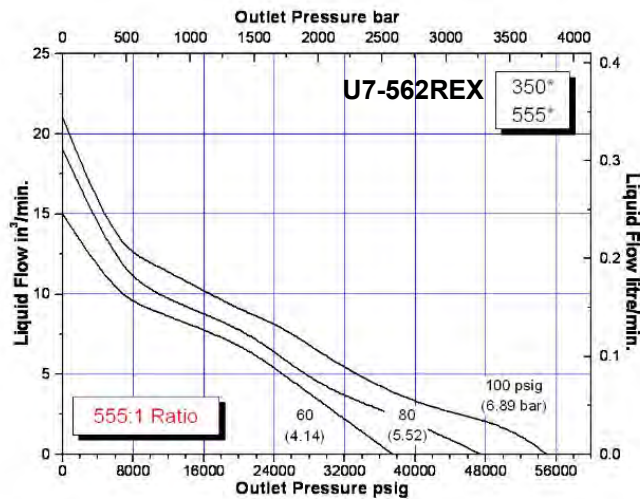
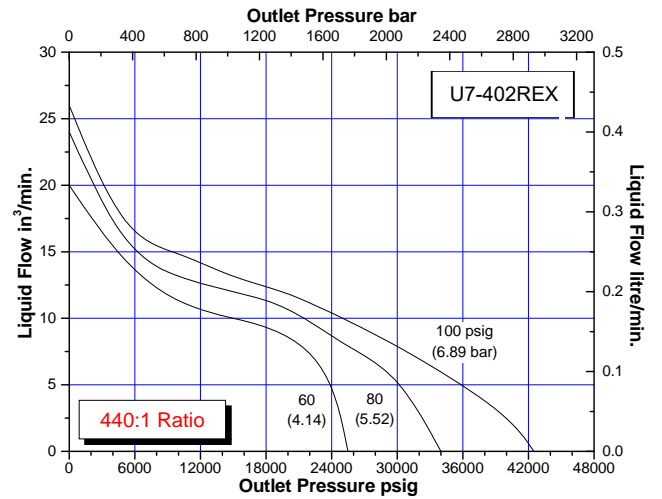
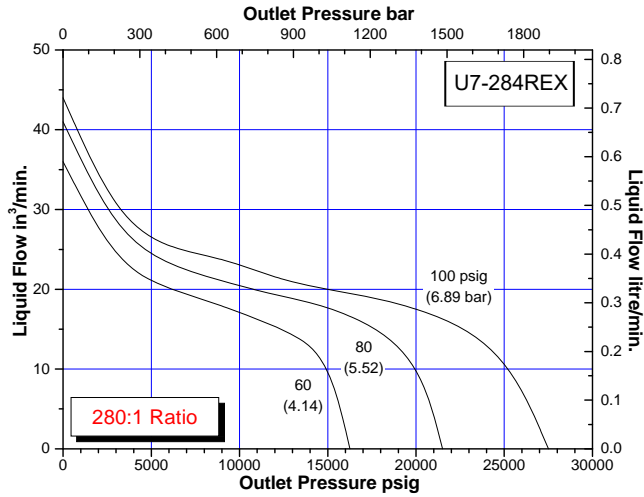

Liquid Pump Cut-a-way

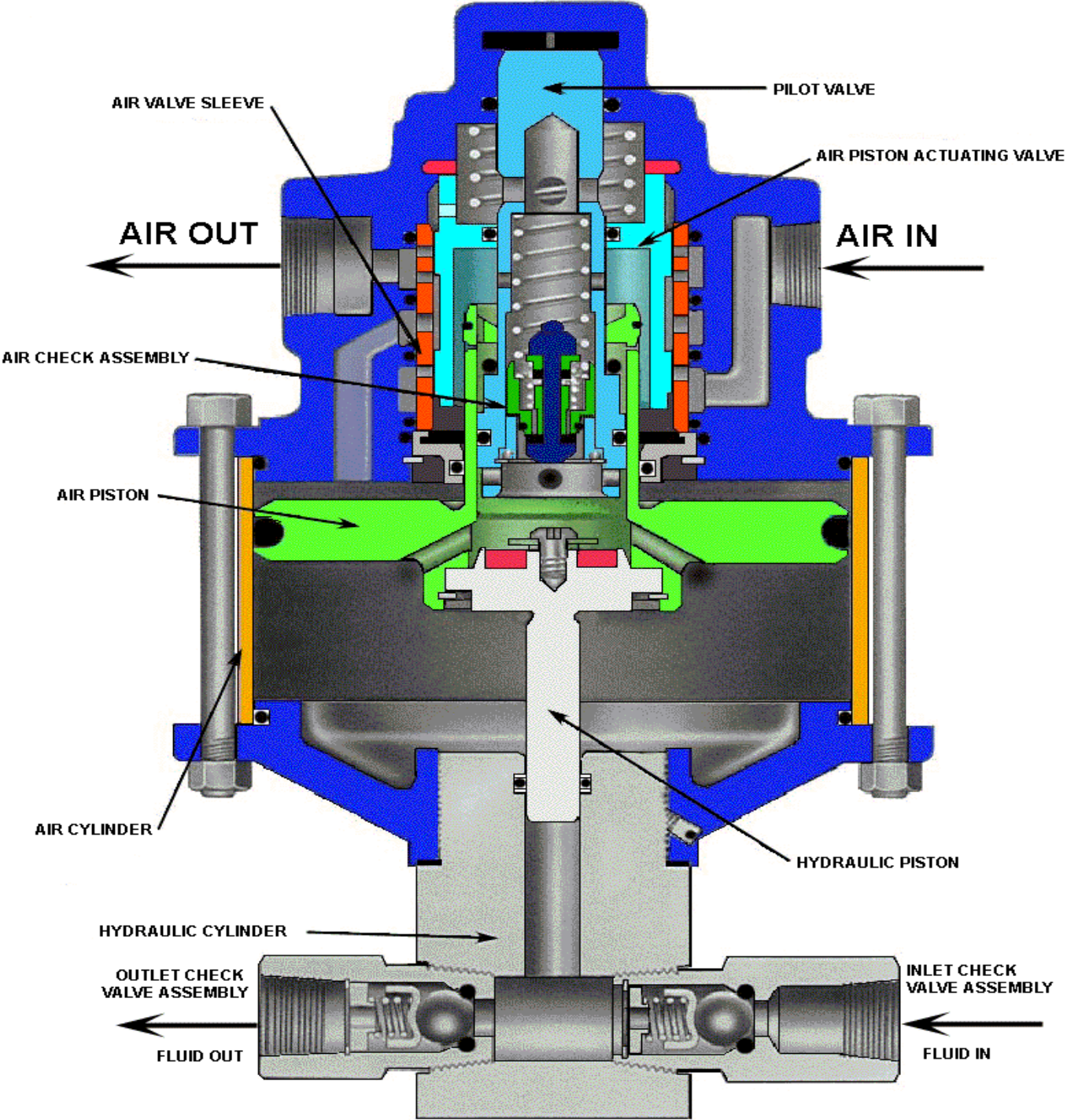

MANUFACTURER'S OPERATING INSTRUCTIONS

SERIES

• Serie U7-REX

PNEUMATIC HYDROSTATIC PRESSURE UNIT

Prior to testing any high pressure line, please check all connections, hoses and fittings to assure that they are properly tightened and in good working order. No frays, tears, or cuts.
REQUIRED: Air compressor capable of 60-100 PSI.

Liquids: Water, Hydraulic, Oils, Glycol and many more.



CONNECTING THE PUMP

1. Connect the output pressure hose provided. Position the Test Pump within 8 feet of test environment.
2. Connect the air line from the compressor to the inlet port on the combination regulator/air filter.

NOTE: AIR FILTER SHOULD BE DRAINED OF ANY WATER OR DIRT PARTICLES BEFORE, AND AFTER USE. Drain valve is located on the bottom of the filter body.

OPERATING THE PUMP

1. Close the pressure return valve (to prevent that the liquid is not circulating and allows us to pressurize)
2. Start the your air shop compressor.
3. Turn on your air compressor, once the compressor has reached operating pressure 100 psi (This will give maximum operating output) Open the air ball valve on unit slowly, which will allow the air to flow to the regulator.
4. Adjust the air regulator, Pull up on the black knob and turn clockwise to increase pressure, or counter-clockwise to decrease pressure. Once the inlet air pressure is set, push down on the knob to lock it in place.
5. Start turning regulator clockwise, pressure will begin building as soon as air flows. When desired test pressure has been met, close the outlet needle valve to isolate test environment. To turn off pump while testing, turn regulator counter clockwise and decrease or stop air flow, or disconnect air compressor supply. If a pressure drop is indicated, check the following:
 - a. Output hose connection at pump.
 - b. Output hose connection at test line.
 - c. Leaking test line or air in the test environment.
7. When you are done with the hydrostatic pressure test run, release and return the pressure to tank open slowly the return valve.

If the pressure gauge remains constant, turn off air ball valve and monitor gauge for your prescribed test time. When test is complete, open the high pressure return/bleeder valve located on control panel, Bleed off the liquid pressure. Repeat the above steps for multiple lines. Be sure the air pressure gauge reads zero before disconnecting the air line from the pump.

LIMITED WARRANTY



6 MONTHS

HYDROREX LLC manufactured products are warranted free of original defects in material and workmanship for a period of one 6 months from date of purchase to first user. This warranty does not include packing, seals or failures caused by lack of proper maintenance, incompatible fluids, foreign materials in the air media, in the fluid media or application of pressures beyond catalog ratings. Products believed to be originally defective may be returned, freight prepaid, for repair and/or replacement to the distributor, authorized service representative or to the factory. If upon inspection by the factory or authorized service representative and the problem is found to be originally defective material or workmanship, repair or replacement will be made at no charge for labor and materials, F.O.B. the point of repair or replacement. Permission to return under warranty should be requested prior to shipment. A Return Material Authorization Number (RMA), the original purchase date, purchase order number, serial number, model number, reason for return or other pertinent data to establish warranty claim must be included in the documentation to expedite the return or replacement to the owner.

If the unit has been disassembled, misused, or altered without prior written authorization, warranty is void. If it has been improperly reassembled or substitute parts have been used in place of factory manufactured parts, warranty is void.

Any modification to any HYDROREX product which you have made or may make in the future will void warranty. HYDROREX disclaims any and all liability obligation, or responsibility for the modified product, and for any claims, demands or causes of action for damage or for personal injuries resulting from the modification and/or use of such a modified HYDROREX product.

HYDROREX obligation with respect to its products shall be limited to replacement, and in no event shall HYDROREX be liable for any loss or damage, consequential or special, of whatever kind or nature, or any other expense which may arise in connection with or as a result of such products or the use or incorporation thereof in a job. This warranty is expressly made in lieu of all other warranties of merchantability and fitness for a particular purpose. No express warranty and no implied warranties whether of merchantability or fitness for a particular purpose or otherwise, other than those expressly set forth above, shall apply to HYDROREX products.