



sales@hydrorex.com - eli@hydrorex.com
Office: 832 277 1182

13360 TELGE RD #401 CYPRESS TEXAS 77429 USA

HIP REX SERIES

HYDROSTATIC UNIT

THE HAND PUMP
ALL STAINLESS ANTICORROSIVE

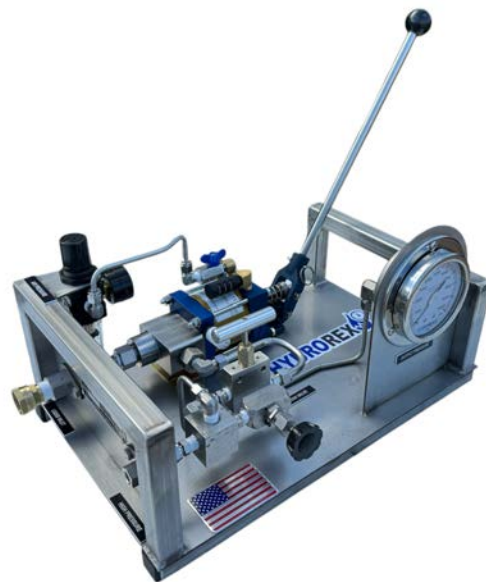

www.hydrorex.com
www.pressureshop.com



P
U
M
P
S

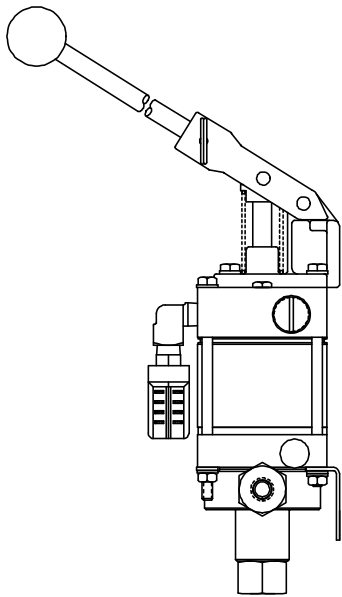

HIP REX SERIES

All Stainless anticorrosive hydrostatic hand pressure pump.

LOW, MEDIUM & HIGH PRESSURE: Is a pneumatic drive system, available in eight models to pressure up to 20,000 Psi (1379 Bar). Compatible with all hydraulic fluids, water, distilled and di-ionized water, solvents, mild chemicals, glycol, liquefied CO2 and many more.

Hand pump and air drive. HIP series pump is self priming for immediate operation.

Hand pump attachment allows for manual operation when shop air is not available or for **precision pressure control**.

Stainless piston allows services water, oils and most corrosive chemicals.

All stainless control components and structure.

Inlet and outlet check valves soft seat with zero leakage.

Made in USA with highest quality components for low operational cost.

For pressure, flow rates and ports size for each model, please download the model datasheet below the product on the web www.hydrorex.com

Components: USA Brands, Parker, Hydro-USA,, SC Hydraulic, Swagelok

- All Stainless Anticorrosive Heavy duty 1" Square tubing
- All Stainless steel, valves, tubing, adapters & hardware
- Hand Pump Operate
- Air Driven 15 – 60 Psi when air operate
- Dry Lube pump does not require and air lubricator
- Pressure output ports will be according to ranges of pressure model, HP, MP, or NPT

Dimensions: 19" Length, 12" High, 12" Width

Weight: 32 Lbs

Shipping Dimensions: 20"L x 12" H x 12" W **Shipping**

Weight: 35 Lbs

HS Code: 8413.50.50

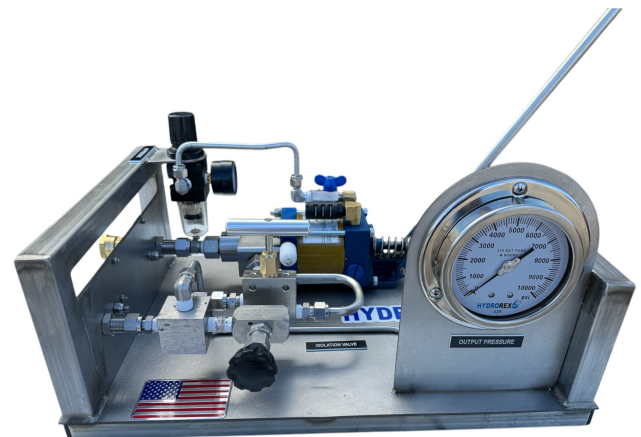

Mounting Dimensions in Inches

Dash Number	L3 Series Models	Max Pressure PSI	Displacement Per Cycle Cu. In.	LIQUID INLET		OUTPUT PRESSURE PORT				
-15	HIP-1800REX	1800	.27	1/2"	FNPT	1/4"	FNPT			
-25	HIP-2700REX	2700	.18	1/2"	FNPT	1/4"	FNPT			
-35	HIP-3500REX	3500	.14	1/2"	FNPT	1/4"	FNPT			
-45	HIP-4800REX	4800	.10	1/2"	FNPT	1/4"	FNPT			
-65	HIP-7000REX	7000	.069	1/2"	FNPT	1/4"	FNPT			
-105	HIP-10000REX	10000	.044	1/2"	FNPT	1/4"	FNPT			
-125	HIP-1300REX	13000	.044	1/2"	FNPT	7/16-20 *	FMP			
-195	HIP-20000REX	20000	.038	1/2"	FNPT	9/16-18	FMP			

When operating from 0 to rated hydraulic pressure, air consumption will be approximately 12-18 scfm of free air at 100 psi output. At lower air pressures and higher hydraulic pressures air consumption will be reduced proportionately to flow rates indicated

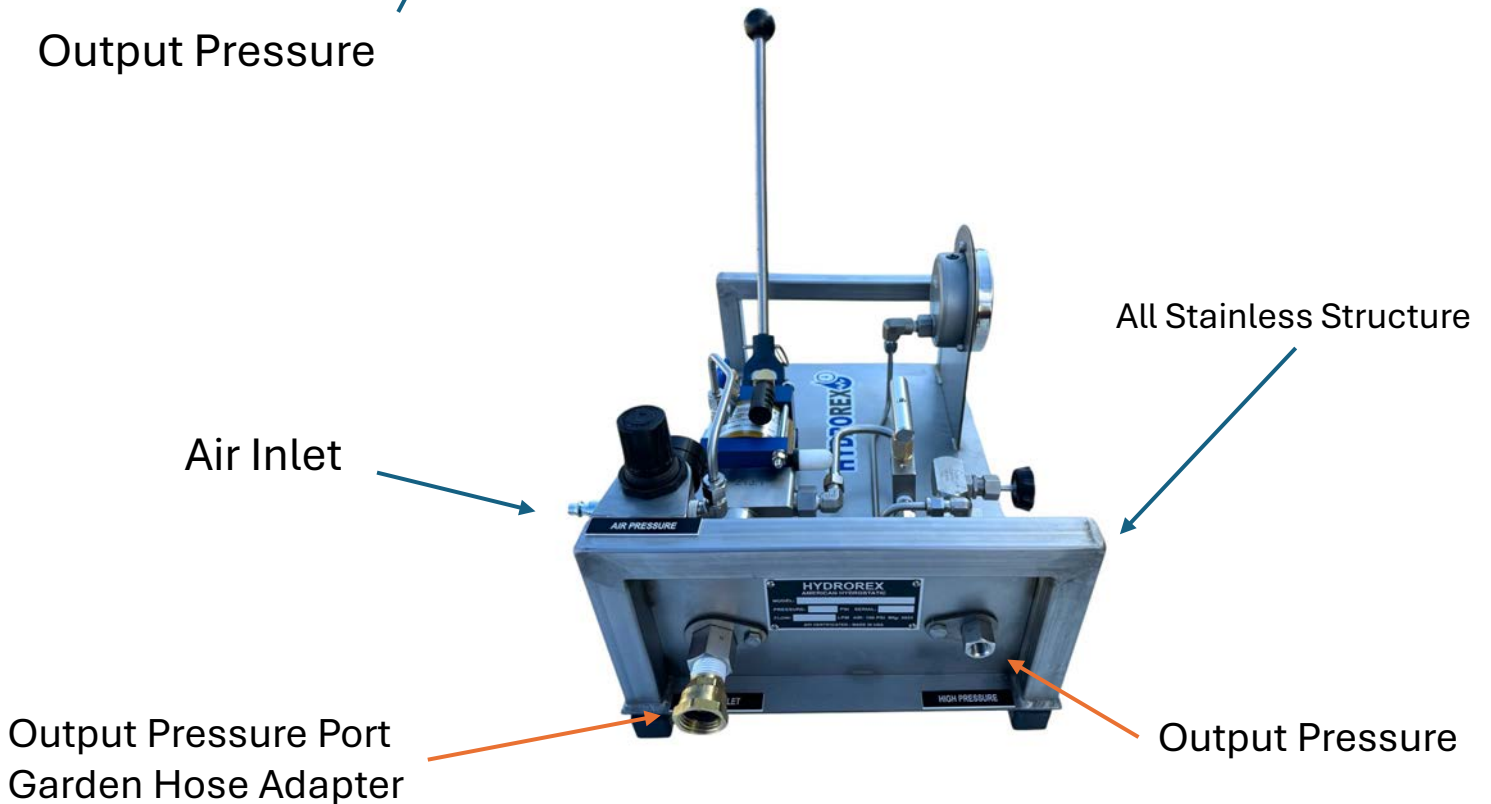
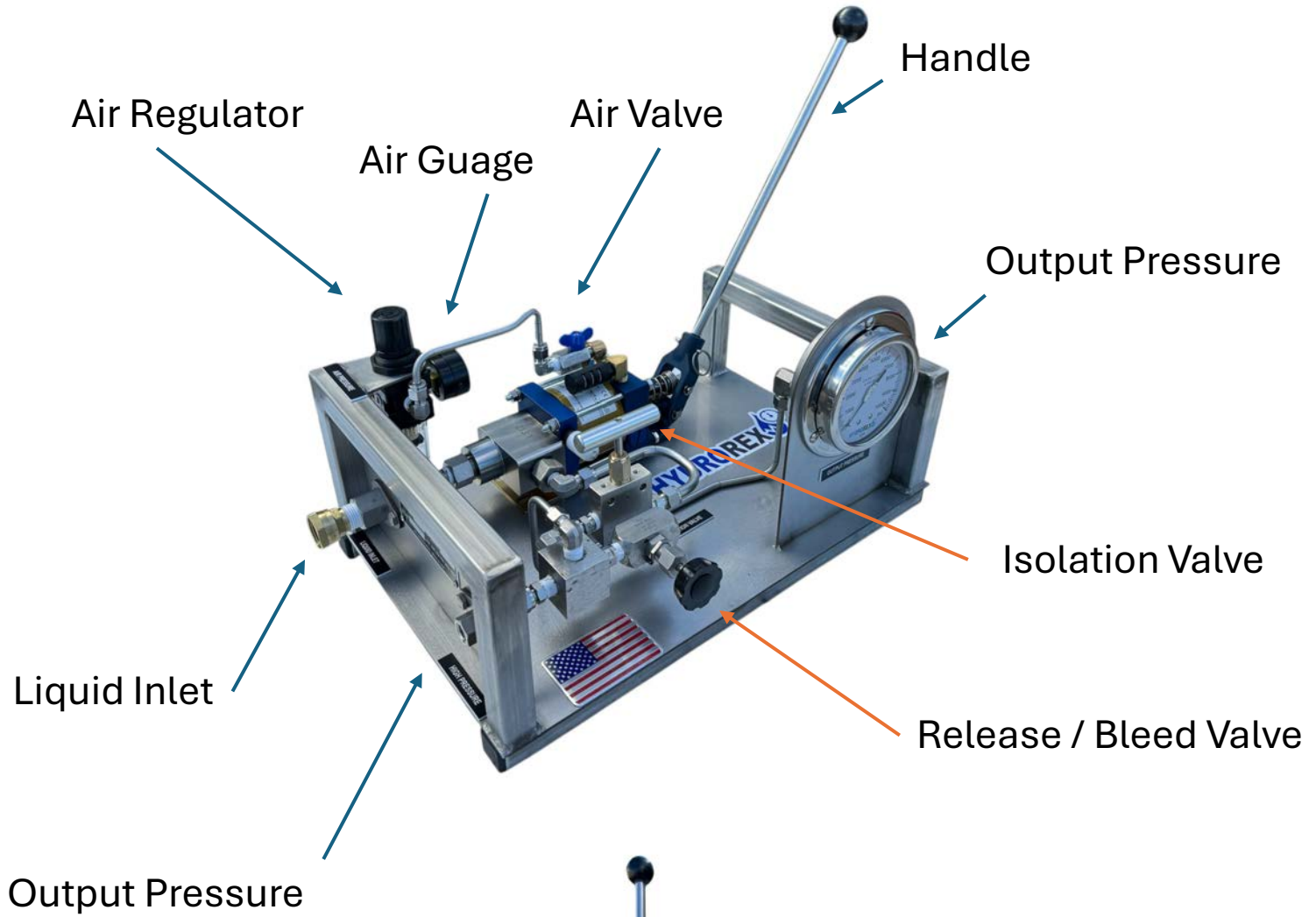



HIP REX SERIES

APPROXIMATE RATE OF DISCHARGE

HIP-1800REX

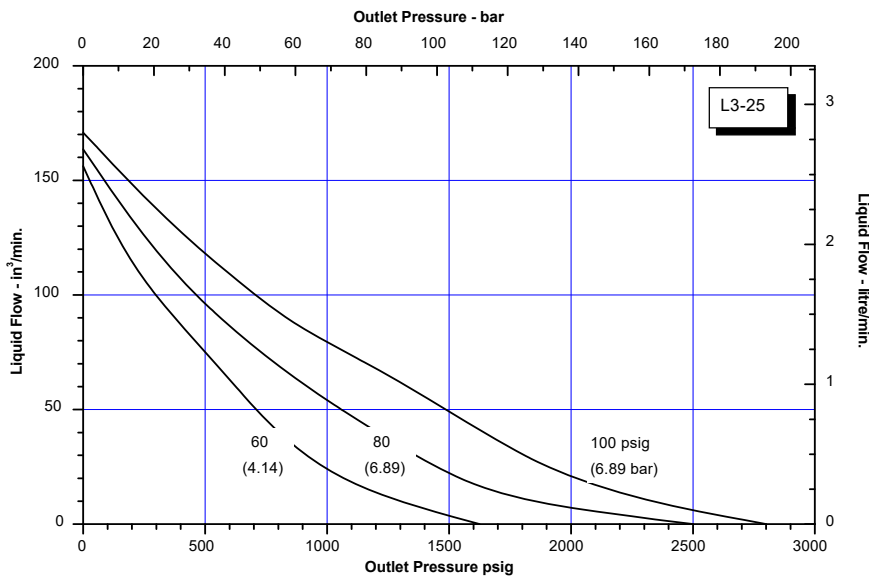
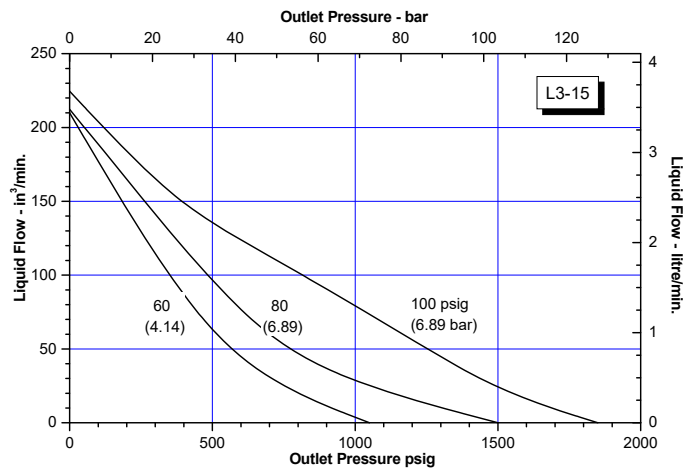

HIP-2700REX

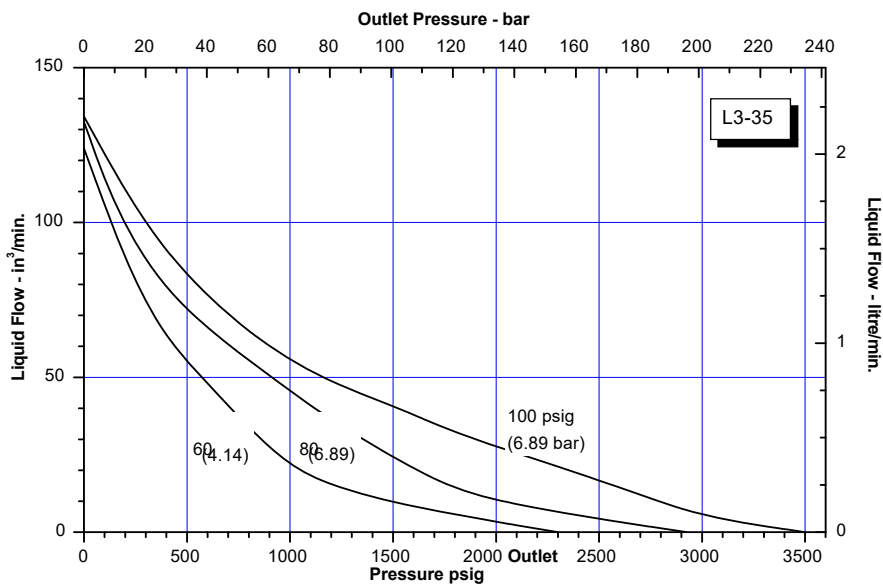

HIP-3500REX

HIP REX SERIES

APPROXIMATE RATE OF DISCHARGE

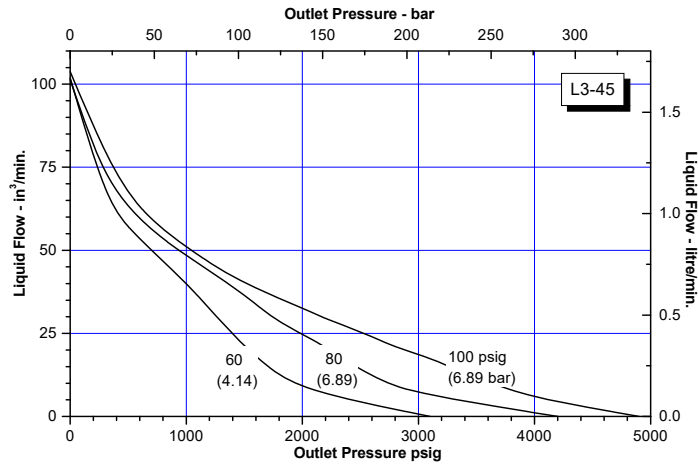

HIP-4800REX

HIP-7000REX

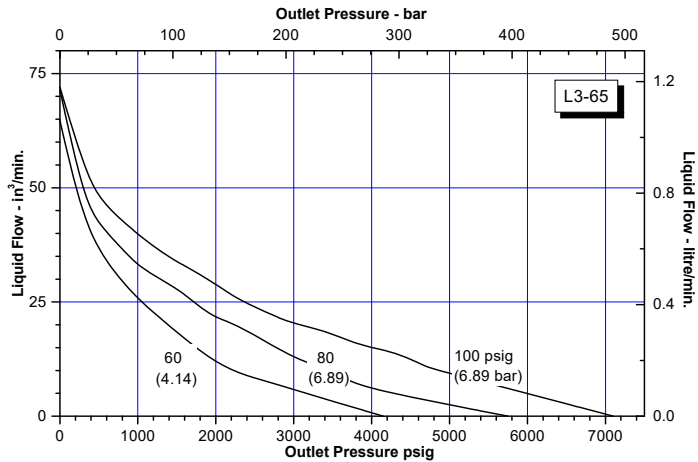

HIP-10000REX

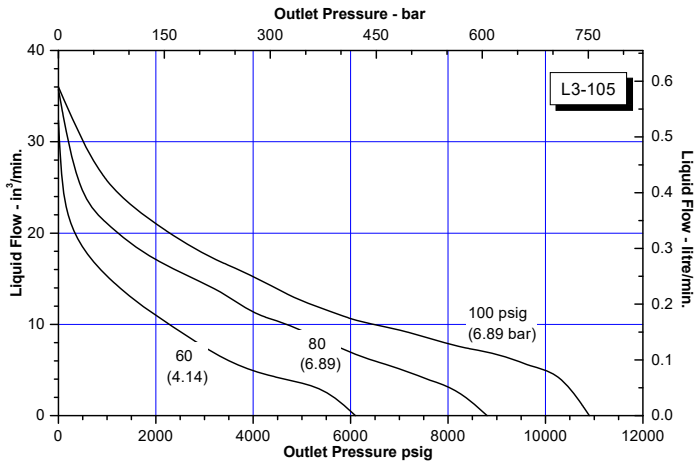

HIP REX SERIES

APPROXIMATE RATE OF DISCHARGE

HIP-13000REX

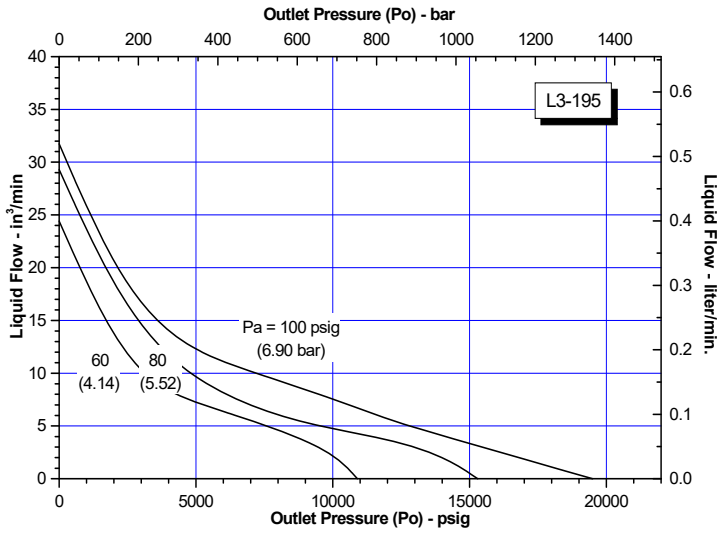
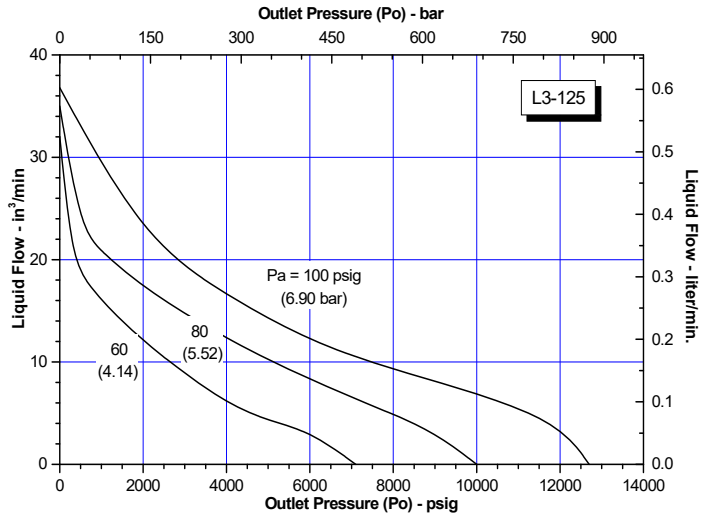

HIP-20000REX

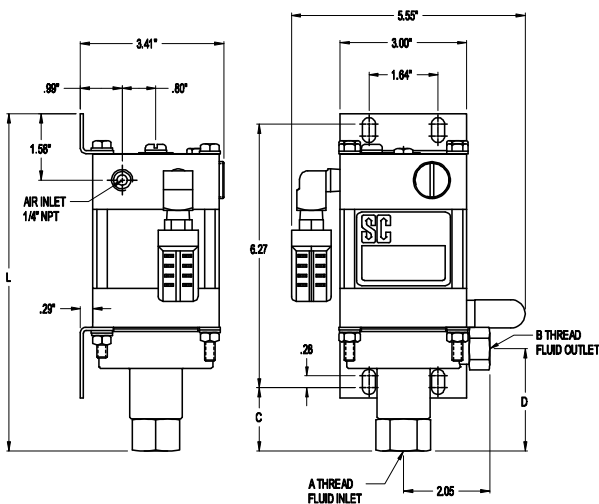

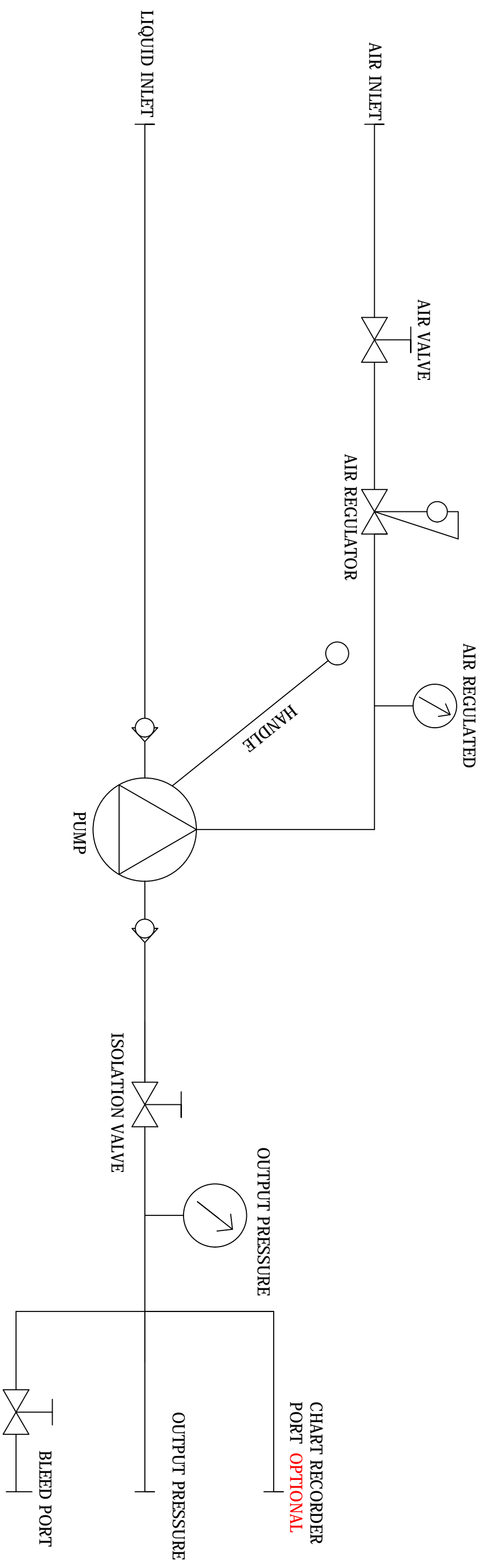

TITLE	HIP FLOW		MATERIAL	STAINLESS STEEL
DRAWN BY	OSCAR GUTIERREZ	APPROVED BY	ELIAS GUTIERREZ	



SCALE	1 / 8	UNITS	IN	SHEET	1
-------	-------	-------	----	-------	---

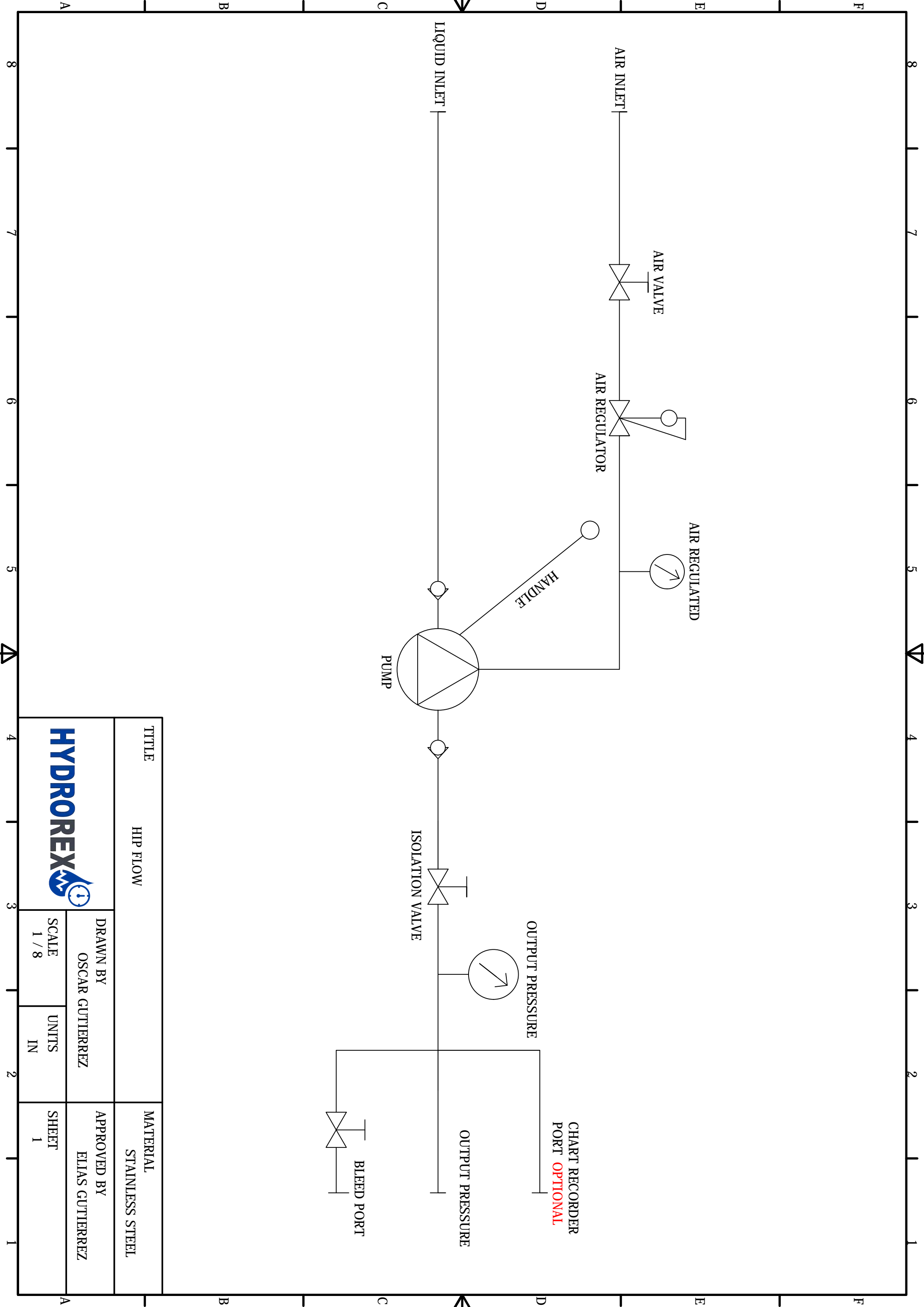

MANUFACTURER'S OPERATING INSTRUCTIONS

SERIES

Model HIP

PNEUMATIC HYDROSTATIC TEST PUMPS

Prior to testing any high pressure line, please check all connections, hoses and fittings to assure that they are properly tightened and in good working order. No frays, tears, or cuts.

REQUIRED: Air compressor capable of 100 PSI, up to

Liquids: Water, Hydraulic, Oils, Glycol and many more.

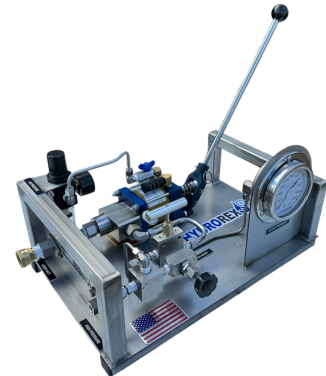

CONNECTING THE PUMP

1. Connect the output pressure hose provided. Position the Test Pump within 8 feet of test environment.
2. Connect the air line from the compressor to the inlet port on the combination regulator/air filter.

NOTE: AIR FILTER SHOULD BE DRAINED OF ANY WATER OR DIRT PARTICLES BEFORE, AND AFTER USE. Drain valve is located on the bottom of the filter body.

OPERATING THE PUMP

1. Fill up the liquid reservoir tank
2. Open the return/bleed valve on the control panel or your test line to bleed off excess air.
NOTE: this should be done several times during test cycle.
3. Start the compressor.
4. Once the compressor has reached operating pressure 100 psi (This will give maximum operating output) open the air ball valve slowly, which will allow the air to flow to the regulator.
5. Adjust the air regulator, Pull up on the black knob and turn clockwise to increase pressure, or counter-clockwise to decrease pressure. Once the inlet air pressure is set, push down on the knob to lock it in place.
6. Start turning regulator clockwise, pressure will begin building as soon as air flows. When desired test pressure has been met, close the outlet Needlevalve to isolate test environment. To turn off pump while testing, turn regulator counter clockwise and decrease or stop air flow, or disconnect air compressor supply. If a pressure drop is indicated, check the following:

Hand pump attachment allows for manual operation shop for precision pressure control.

- a. Output hose connection at pump.
- b. Output hose connection at test line.
- c. Leaking test line or air in the test environment.

If the pressure gauge remains constant, turn off air ball valve and monitor gauge for your prescribed test time. When test is complete, open the high pressure return/bleeder valve located on control panel, Bleed off the liquid pressure. Repeat the above steps for multiple lines. Be sure the air pressure gauge reads zero before disconnecting the air line from the pump.

LIMITED WARRANTY



6 MONTHS

HYDROREX LLC manufactured products are warranted free of original defects in material and workmanship for a period of one 6 months from date of purchase to first user. This warranty does not include packing, seals or failures caused by lack of proper maintenance, incompatible fluids, foreign materials in the air media, in the fluid media or application of pressures beyond catalog ratings. Products believed to be originally defective may be returned, freight prepaid, for repair and/or replacement to the distributor, authorized service representative or to the factory. If upon inspection by the factory or authorized service representative and the problem is found to be originally defective material or workmanship, repair or replacement will be made at no charge for labor and materials, F.O.B. the point of repair or replacement. Permission to return under warranty should be requested prior to shipment. A Return Material Authorization Number (RMA), the original purchase date, purchase order number, serial number, model number, reason for return or other pertinent data to establish warranty claim must be included in the documentation to expedite the return or replacement to the owner.

If the unit has been disassembled, misused, or altered without prior written authorization, warranty is void. If it has been improperly reassembled or substitute parts have been used in place of factory manufactured parts, warranty is void.

Any modification to any HYDROREX product which you have made or may make in the future will void warranty. HYDROREX disclaims any and all liability obligation, or responsibility for the modified product, and for any claims, demands or causes of action for damage or for personal injuries resulting from the modification and/or use of such a modified HYDROREX product.

HYDROREX obligation with respect to its products shall be limited to replacement, and in no event shall HYDROREX be liable for any loss or damage, consequential or special, of whatever kind or nature, or any other expense which may arise in connection with or as a result of such products or the use or incorporation thereof in a job. This warranty is expressly made in lieu of all other warranties of merchantability and fitness for a particular purpose. No express warranty and no implied warranties whether of merchantability or fitness for a particular purpose or otherwise, other than those expressly set forth above, shall apply to HYDROREX products.