



13360 Telge Rd Bulding # 606 Cypress Texas 77429 USA

AIR OPERATED GAS BOOSTERS & SYSTEMS

SS-GB Series



For transfer and pressurization of a wide range of gases, Oxygen, Nitrogen, Helium, CO₂, Hydrogen, Argon and Breathing Air.

B
O
O
S
T
E
R

AIR DRIVEN GAS BOOSTERS

Hydrorex air driven gas boosters are self-contained units, using a cycling spool and pilot valve to provide automatic reciprocating action when air or gas is supplied to the air drive inlet.

The drive consists of a large piston and valve assembly directly connected to a *hydrocarbon-free pumping piston* with self lubricating seals cycling in a stainless barrel that has an integral check valve.

The working surface area of the drive piston exceeds the working surface area of the pump piston, thereby providing the pressure BOOST. This is accomplished by using relatively low pressure air or

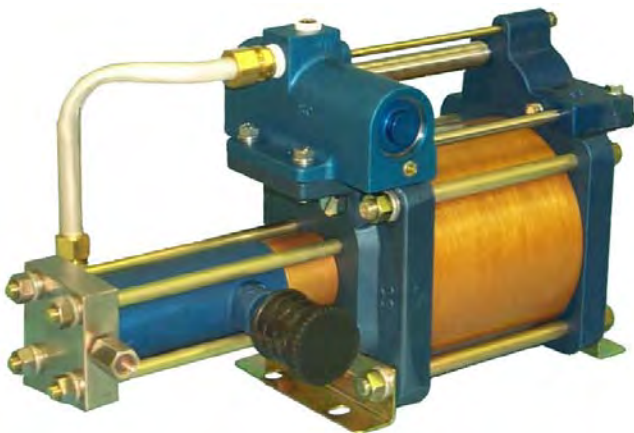

gas to the drive inlet. The air drive section is pre-lubricated (thus eliminating the need for an air line lubricator), easy to install, and can be mounted in any position eliminating additional floor space. No electrical connections are required.

Hydrorex gas boosters are typically used to boost low pressure gas/air to a higher pressure required at the process or test station. Most industrial gases (nitrogen, helium, hydrogen, argon, etc.) are commonly delivered under pressure in steel cylinders. If gas is to be used at low pressures, e.g., welding, the pressurized supply is easily piped and controlled to the point of use with simple valving. However, if the end use requires the gas under pressure, the supply cylinder pressure cannot be utilized after it has fallen to the level of the end use pressure. Therefore, the gas remaining will be wasted unless it is boosted.

If the application requires a pressure greater than the common supply cylinder pressure, a gas booster **must** be used. Depending on the unit selected, you can boost gas pressure from 25 psi and up to 25,000 psi.

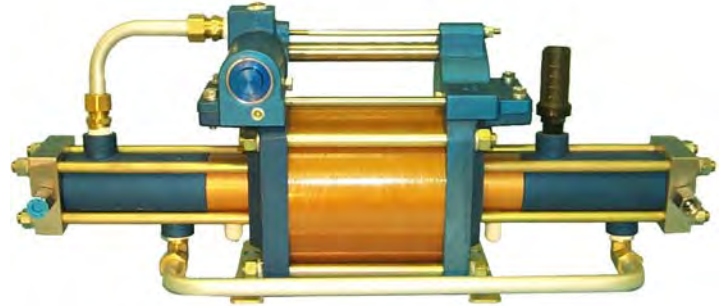

Hydrorex gas boosters are suitable for other applications such as bottle filling from nitrogen generators and dewars, hydrogas suspension systems, automotive air gas storage systems, aircraft slide chute gas storage; sulfur hexafluoride (SF6) transfer for arc suppression and insulation of circuit breakers commonly found in the utility industry, gas injection molding, etc.

In addition to our complete line of gas boosters, Hydrorex also fabricates custom gas booster systems for individual applications. These units are manufactured to customer specifications and can include filters,



gauges, pilot switches, panel controls, tubular frames, etc. Contact your distributor or our sales department for more information.

To assist in selecting the best gas booster for your application Hydrorex offers a free service for sizing units. Just send us your requirements needs to eli@hydrorex.com.

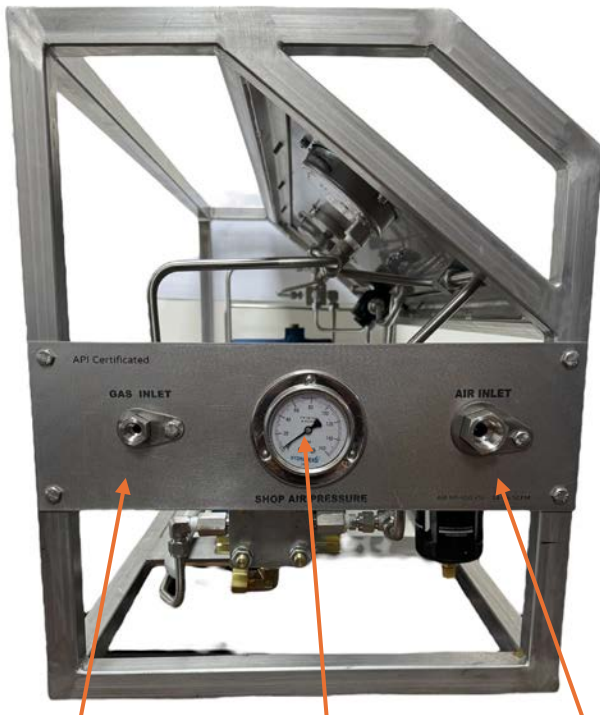
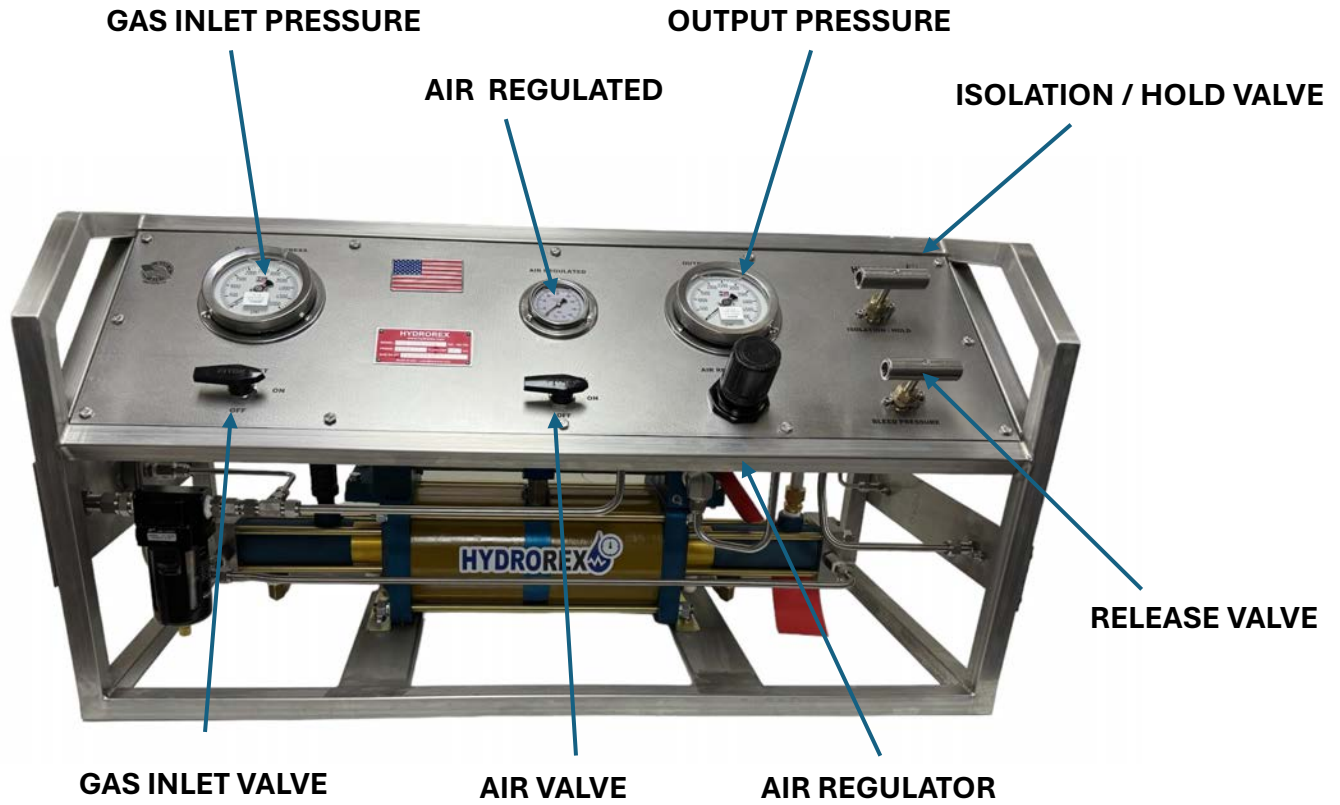

**AIR INLET PORT
1/2 FEMALE NPT**

AIR INLET PRESSURE

**GAS INLET PORT
1/4 FEMALE NPT**



**OUTPUT PRESURE PORT
1/4 FNPT, 3/8 FMP OR 1/4 FHP
ACCORDING TO MODEL**

**RELEASE PORT
1/4 FEMALE NPT**

Selecting the Right Booster for Your Application

We could fill several pages of formulas, tables, and explanations of how to determine the best, most economical booster for your application.

After plowing through all the information, including types of gas, decaying supply versus constant, displacement factors, volumetric efficiencies and compression ratios, just to name a few, you may still wonder if you are making the right choice.



GLOSSARY OF TERMS

Pa (Air Drive Pressure)

Pressure from air/gas compressor available at the booster to drive the unit. If the pressure fluctuates, the lowest pressure available is used to calculate the output gas pressure. The Pa, and in some selections, along with the supply pressure will determine the maximum stall pressure of the booster.

Va (Air Drive Flow)

Volume of air/gas measured in SCFM (standard cubic feet per minute) available to drive the unit. The volume of air/gas determines the speed in which the booster will cycle and therefore the volume delivered from the outlet port. The volume of outlet gas also determines the speed in which a vessel is filled to a static pressure.

CPM (Air Drive Speed)

Cycles per minute when operating the booster, which is determined by the volume of drive air/gas available. The CPM is highest when starting to fill a vessel and decreases as the output pressure increases until reaching the static or stall pressure.

Ps (Gas Supply Pressure)

Pressure of the gas from the supply source. If the supply is from a gas generator or very large source, the Ps may be considered constant. If from a smaller source, typically bottles, the Ps will decrease as the supply is used. The decrease in supply will affect the static pressure output (in certain boosters) and the fill time or SCFM of the output.

Vs (Gas Supply Volume)

Volume of the gas available from the supply source. This is measured not by SCFM but by ACF (actual cubic feet) or water volume of the source. If the supply is from a gas generator or very large source, the Vs may be considered unlimited. The ACF of the supply determines how many fills to a certain static pressure can be made until the source is depleted.

Po (Gas Outlet Stall Pressure)

Pressure of the gas at the outlet. This can be stated as an output pressure at a certain SCFM or as the static output stall pressure when filling a vessel.

Vo (Gas Outlet Flow)

The volume of gas delivered at the outlet port measured in SCFM. This can be converted to ACFM if the temperature of the output gas is known using the formula: $ACFM = SCFM \times 14.696 / (Pa + 14.696) \times \text{degrees F.} / 530$

GB SERIES

Single Stage-Single Acting Booster



The GB series is the most economical of the SC Hydraulic Gas Boosters and is ideal for applications not requiring much volume such as pressure testing small vessels or components. Pressures can be boosted from as low as 50 psig and up to over 11,000 psig.

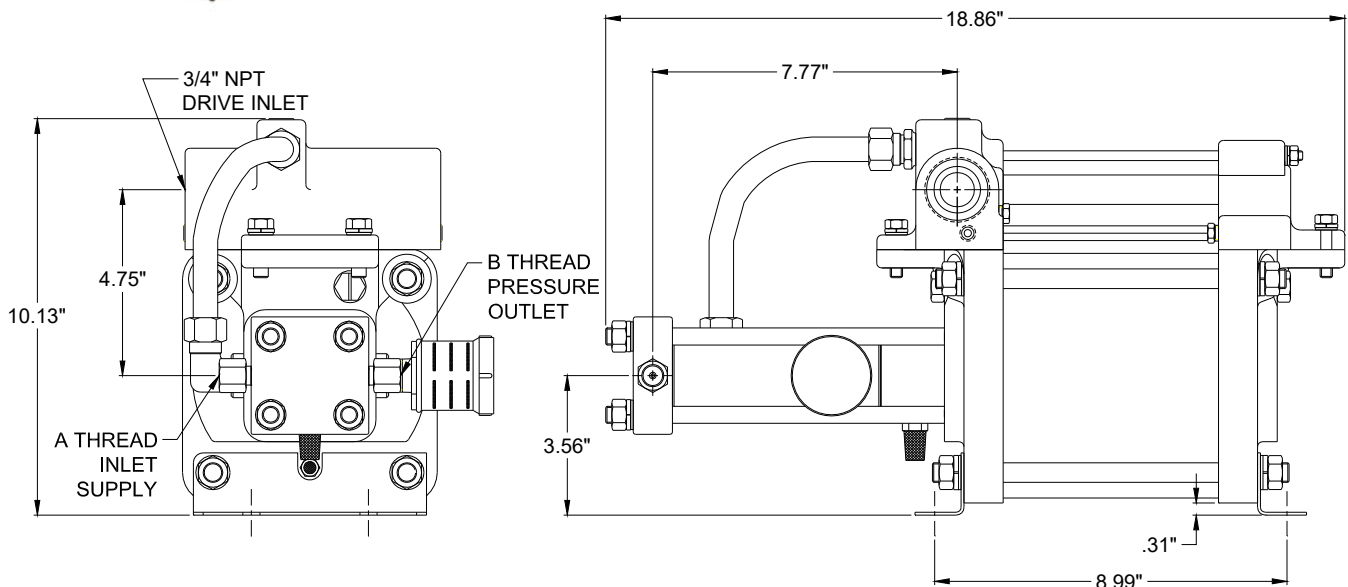

Model No.	Maximum Material Rated Gas Supply Pressure (Ps)	Maximum Material Rated Gas Outlet Pressure (Po)	Inlet Port (A) Outlet Port (B)	Static Outlet Stall Pressure	Minimum Inlet Gas Pressure (Ps)	Displacement Per Stroke (in ³ per cycle)
GB-15	2,250 psig 155 bar	2,250 psig 155 bar	1/4" NPT 1/4" NPT	15 Pa	50 psig (3.5 bar)	7.05
GB-30	4,500 psig 310 bar	4,500 psig 310 bar	1/4" NPT 1/4" NPT	30 Pa	100 psig (7 bar)	3.1
GB-75	6,000 psig 410 bar	11,250 psig 775 bar	9/16"-18 ⁽¹⁾ 9/16"-18 ⁽¹⁾	75 Pa	250 psig (17 bar)	1.2

- (1) Coned and Threaded High Pressure Connection for 1/4" O.D. Tubing.
2. Refer to corresponding gas booster performance curve for operating pressures (see page 9 to 20).
3. Maximum material rated outlet pressures can be reached under special operating conditions. Do not use air drive or/and gas supply pressures that equate to higher outlet pressures than those "maximum material rated outlet pressures" shown on table. Refer to Static Outlet Stall Pressure formula shown on table (for example, for gas booster model GBD-30 the formula is: Static Outlet Stall Pressure = 30*Pa+Ps).
4. Maximum recommended air drive operating pressure: 100-psi.
5. Maximum rated air drive pressure: 150-psi (only for static outlet stall pressure).
6. Maximum allowed working pressure for oxygen service boosters: 5,000-psi max.
7. Maximum allowed working pressure for hydrogen service boosters : 6,000-psi max.
8. Oxygen & hydrogen service boosters not available on all models. Contact factory for more information.

For assistance in selecting the proper Gas Booster complete and fax the data work sheet or e-mail inquiries to eli@hydrorex.com

GB SERIES

Single Stage-Single Acting Booster

SS-GB-15

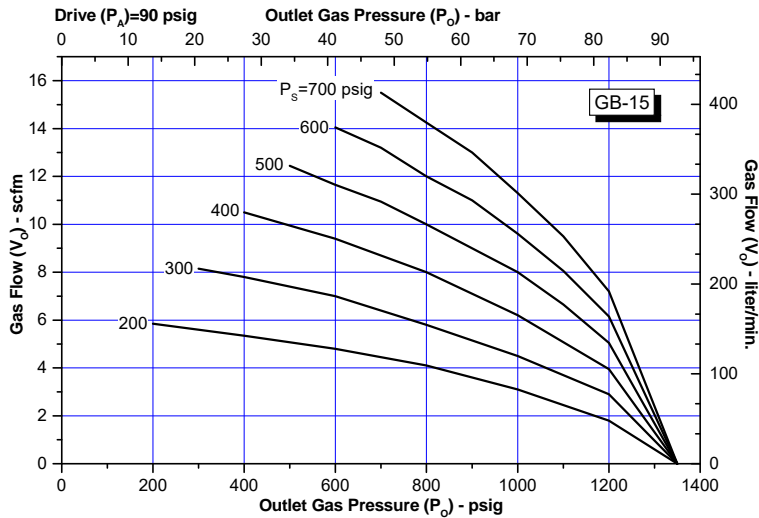

Legend
 PA = Drive Pressure
 PO = Gas Outlet Pressure
 PS = Gas Inlet Pressure
 VO = Output Gas Flow

NOTE:
 Performance charts are for reference only.

The curves are based on an Air Drive (P_A) of 90 psig and a maximum air consumption of 72-scfm. If the P_A is higher or lower, the Outlet gas pressure (P_o) can change significantly.

Also, the supply pressures (P_s) shown in the graphs are based on constant pressure being supplied as the pressure is boosted. A supply from cylinders or bottles will affect the pressure outlet (P_o) and flow (V_o) as the supply pressure (P_s) is depleted.

Contact SC Hydraulic Engineering for detailed performance data on any

SS-GB-30

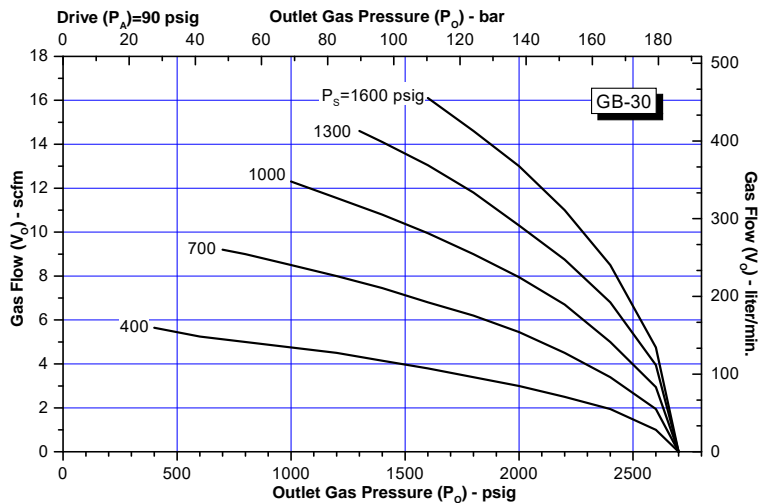

SS-GB-75

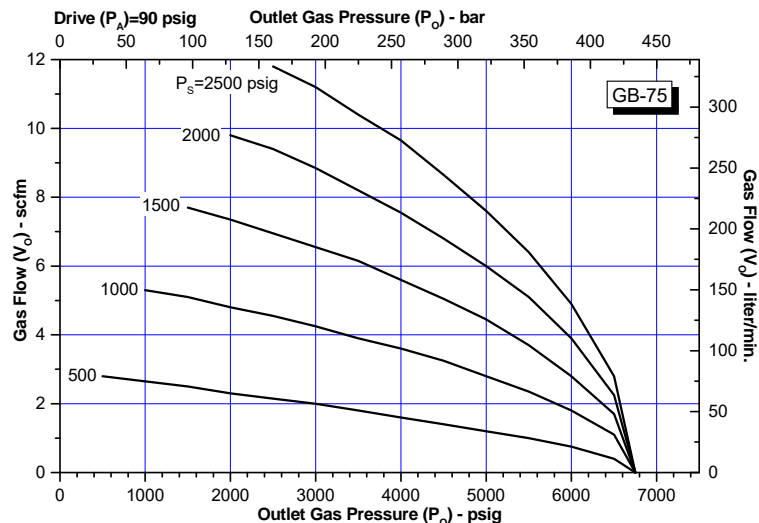

GB-D SERIES

Single Stage-Single Acting Double Head Booster

This series has the same characteristics of the standard GB Series however the double head allows half the input pressure to achieve the same outlet pressure.

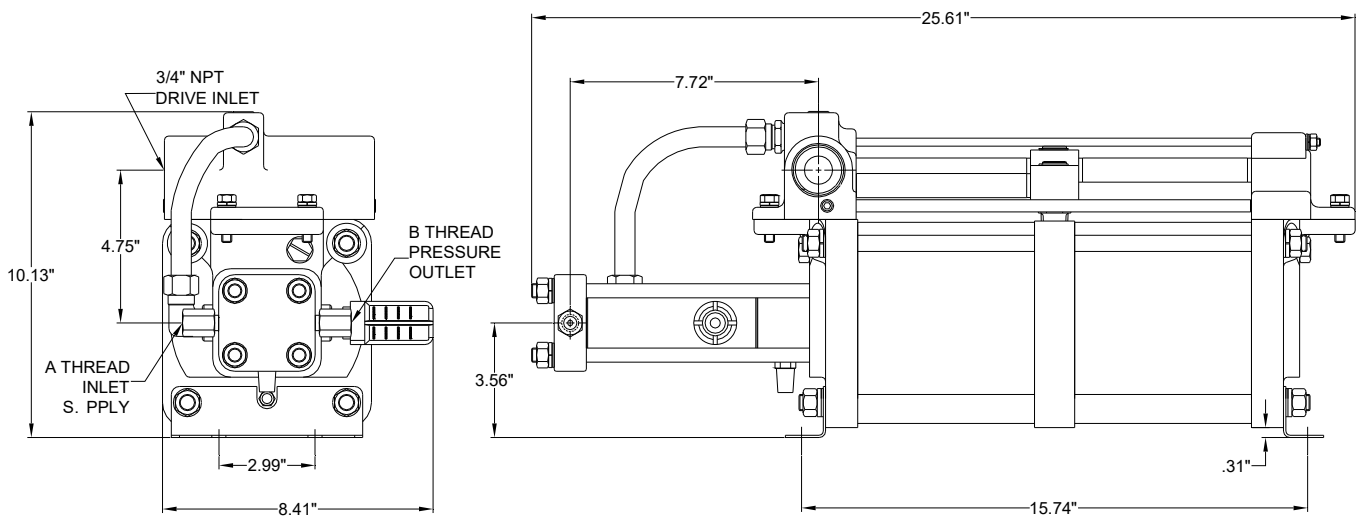

Model No.	Maximum Material Rated Gas Supply Pressure (Ps)	Maximum Material Rated Gas Outlet Pressure (Po)	Inlet Port (A) Outlet Port (B)	Static Outlet Stall Pressure	Minimum Inlet Gas Pressure (Ps)	Displacement Per Stroke (in ³ per cycle)
GB-D30	6,000 410 bar	9,000 620 bar	1/4" NPT 1/4" NPT	60 Pa	200 psig (13 bar)	3.1
GB-D75	6,000 410 bar	20,000 psig 1,380 bar	9/16"-18 ⁽¹⁾ 9/16"-18 ⁽¹⁾	150 Pa	250 psig (17 bar)	1.2

- (1) Coned and Threaded High Pressure Connection for 1/4" O.D. Tubing.
2. Refer to corresponding gas booster performance curve for operating pressures (see page 9 to 20).
3. Maximum material rated outlet pressures can be reached under special operating conditions. Do not use air drive or/and gas supply pressures that equate to higher outlet pressures than those "maximum material rated outlet pressures" shown on table. Refer to Static Outlet Stall Pressure formula shown on table (for example, for gas booster model GBD-30 the formula is: Static Outlet Stall Pressure = 30*Pa+Ps).
4. Maximum recommended air drive operating pressure: 100-psi.
5. Maximum rated air drive pressure: 150-psi (only for static outlet stall pressure).
6. Maximum allowed working pressure for oxygen service boosters: 5,000-psi max.
7. Maximum allowed working pressure for hydrogen service boosters : 6,000-psi max.
8. Oxygen & hydrogen service boosters not available on all models. Contact factory for more information.

For assistance in selecting the proper Gas Booster complete and fax the data work sheet or e-mail inquires to eli@hydrorex.com

GB-D SERIES

Single Stage-Single Acting Double Head Booster

SS-GB-D30

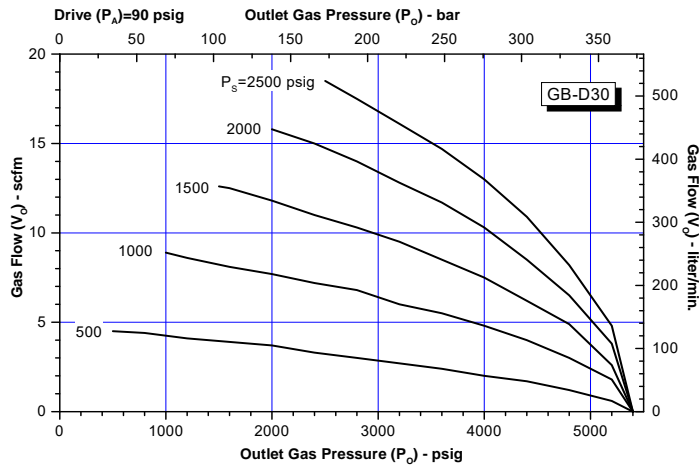

Legend

PA = Drive Pressure
 PO = Gas Outlet Pressure
 PS = Gas Inlet Pressure
 VO = Output Gas Flow

NOTE:
 Performance charts are for reference only.

The curves are based on an Air Drive (P_a) of 90 psig and a maximum air consumption of 72-scfm. If the P_a is higher or lower, the Outlet gas pressure (P_o) can change significantly.

Also, the supply pressures (P_s) shown in the graphs are based on constant pressure being supplied as the pressure is boosted. A supply from cylinders or bottles will affect the pressure outlet (P_o) and flow (V_o) as the supply pressure (P_s) is depleted.

Contact SC Hydraulic Engineering for detailed performance data on any

SS-GB-D75

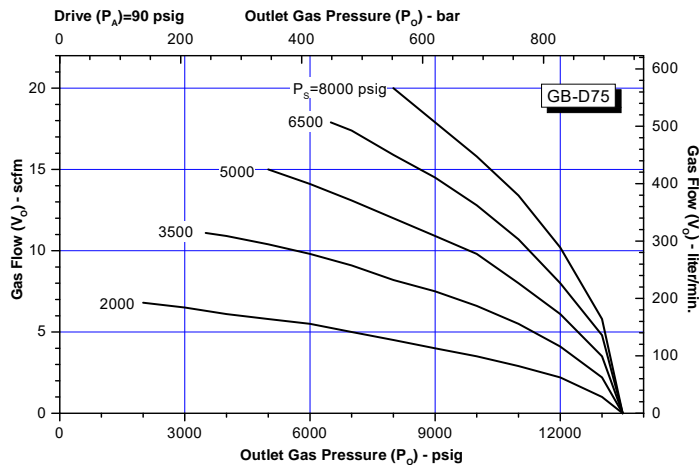

GBD-5

Single Stage-Double Acting Booster

This gas booster is a modified version of our popular ABD air booster. It is used to boost gas pressures up to 1,500 psig. The booster is able to move large volumes of gas efficiently when lower pressures are suitable. For convenience, the graph illustrates various inlet gas supplies with matching air drive pressures.

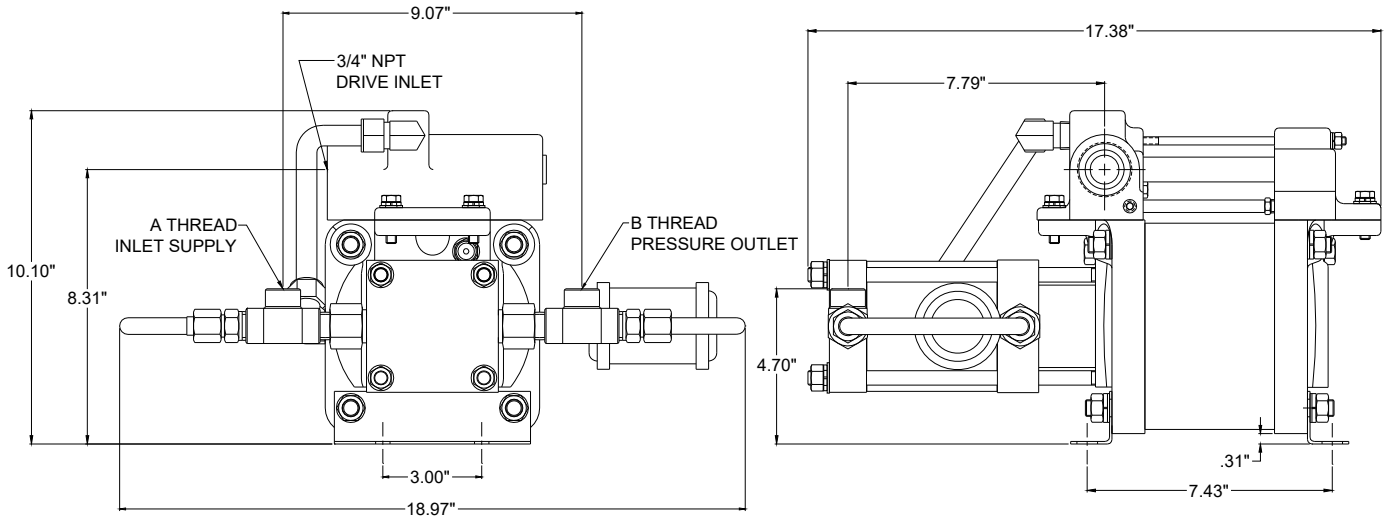

Model No.	Maximum Material Rated Gas Supply Pressure (Ps)	Maximum Material Rated Gas Outlet Pressure (Po)	Inlet Port (A) Outlet Port (B)	Static Outlet Stall Pressure	Minimum Inlet Gas Pressure (Ps)	Displacement Per Stroke (in3 per cycle)
GBD-5	1500 psig 103 bar	1500 103 bar	1/2" NPT 1/2" NPT	4.7 Pa +Ps	25 psig	28.2

Legend
 PA = Drive Pressure
 PO = Gas Outlet Pressure
 PS = Gas Inlet Pressure
 VO = Output Gas Flow

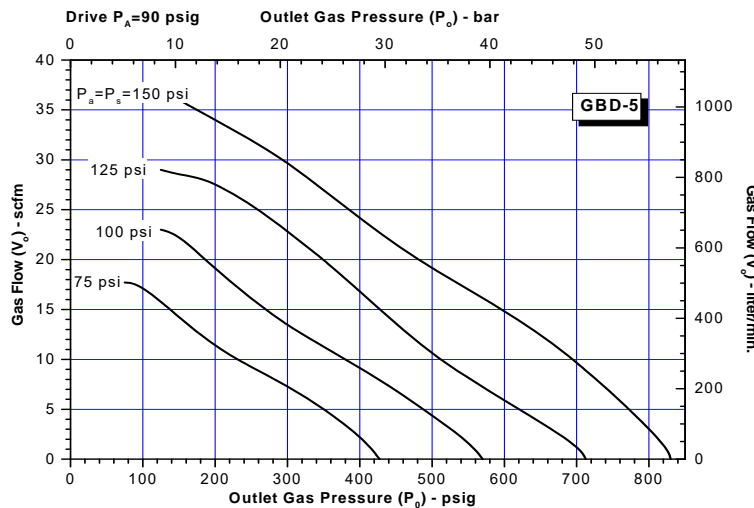

SS-GBD-5

See NOTE on Page 13 regarding Performance Charts

For assistance in selecting the proper Gas Booster complete and fax the data work sheet or e-mail inquires to eli@hydrorex.com

GBD SERIES

Single Stage-Double Acting Booster

This series of boosters doubles the volume of output gas per cycle and is a good choice for moving relatively high volumes at pressures up to 20,000 psig. Supply pressure is added to the maximum outlet pressure.

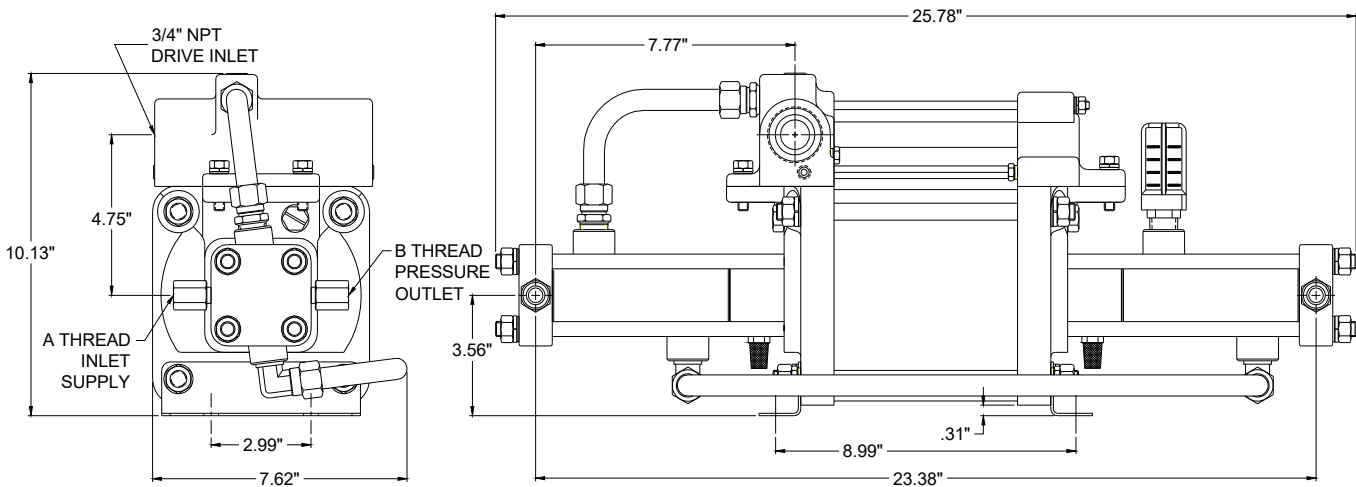

Model No.	Maximum Material Rated Gas Supply Pressure (Ps)	Maximum Material Rated Gas Outlet Pressure (Po)	Inlet Port (A) Outlet Port (B)	Static Outlet Stall Pressure	Minimum Inlet Gas Pressure (Ps)	Displacement Per Stroke (in ³ per cycle)
GBD-15	5,000 psig 345 bar	5,000 psig 345 bar	1/4" NPT 1/4" NPT	15 Pa + Ps	50 psig (3.5 bar)	14.1
GBD-30	6,000 psig 410 bar	9,000 psig 620 bar	1/4" NPT 1/4" NPT	30 Pa + Ps	100 psig (7 bar)	6.3
GBD-75	6,000 psig 410 bar	20,000 psig 1,380 bar	9/16"-18 ⁽¹⁾ 9/16"-18 ⁽¹⁾	75 Pa + Ps	250 psig (17 bar)	2.4

- (1) Coned and Threaded High Pressure Connection for 1/4" O.D. Tubing.
2. Refer to corresponding gas booster performance curve for operating pressures (see page 9 to 20).
3. Maximum material rated outlet pressures can be reached under special operating conditions. Do not use air drive or/and gas supply pressures that equate to higher outlet pressures than those "maximum material rated outlet pressures" shown on table. Refer to Static Outlet Stall Pressure formula shown on table (for example, for gas booster model GBD-30 the formula is: Static Outlet Stall Pressure = 30*Pa+Ps).
4. Maximum recommended air drive operating pressure: 100-psi.
5. Maximum rated air drive pressure: 150-psi (only for static outlet stall pressure).
6. Maximum allowed working pressure for oxygen service boosters: 5,000-psi max.
7. Maximum allowed working pressure for hydrogen service boosters : 6,000-psi max.
8. Oxygen & hydrogen service boosters not available on all models. Contact factory for more information.

GBD SERIES

Single Stage-Double Acting Booster

Legend
 PA = Drive Pressure
 PO = Gas Outlet Pressure
 PS = Gas Inlet Pressure
 VO = Output Gas Flow

NOTE:
 Performance charts are for reference only.

The curves are based on an Air Drive (Pa) of 90 psig and a maximum air consumption of 72-scfm. If the Pa is higher or lower, the Outlet gas pressure (Po) can change significantly.

Also, the supply pressures (Ps) shown in the graphs are based on constant pressure being supplied as the pressure is boosted. A supply from cylinders or bottles will affect the pressure outlet (Po) and flow (Vo) as the supply pressure (Ps) is depleted.

Contact SC Hydraulic Engineering for detailed performance data on any

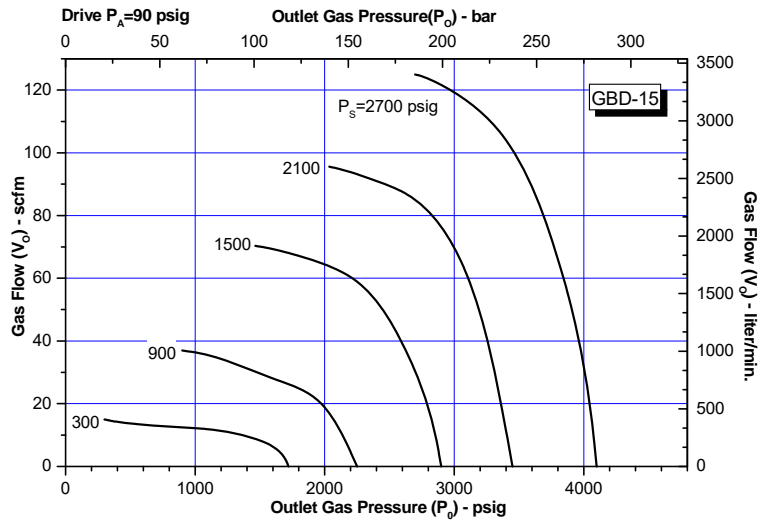

SS-GBD-15

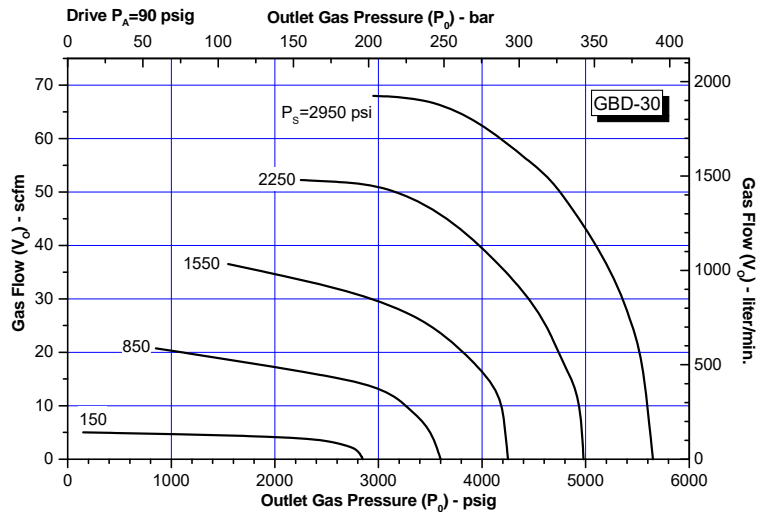

SS-GBD-30

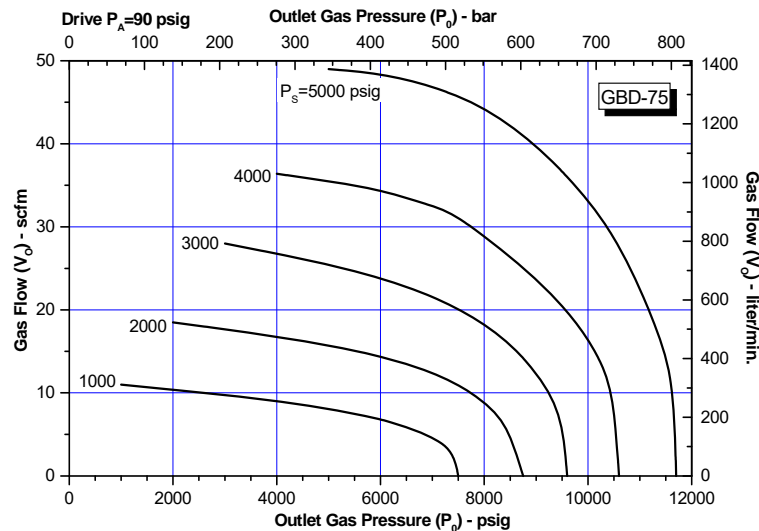

SS-GBD-75

GBD-D SERIES

Double Acting-Double Head Booster

This series has the same characteristics of the standard GBD however the double head allows half the input pressure to achieve the same outlet pressure.

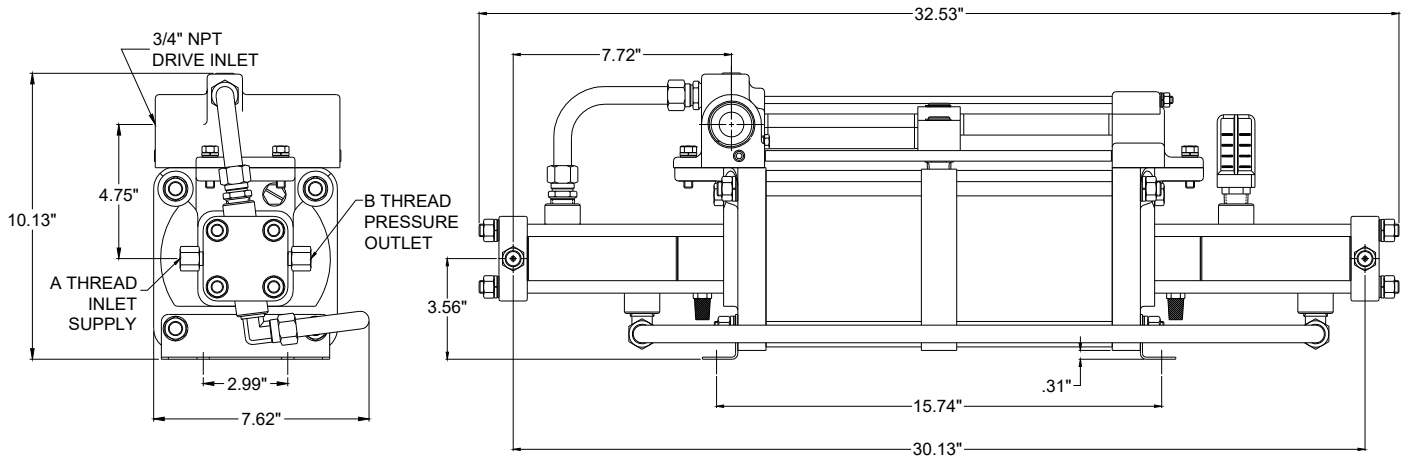

Model No.	Maximum Material Rated Gas Supply Pressure (Ps)	Maximum Material Rated Gas Outlet Pressure (Po)	Inlet Port (A) Outlet Port (B)	Static Outlet Stall Pressure	Minimum Inlet Gas Pressure (Ps)	Displacement Per Stroke (in3 per cycle)
GBD-D15	5,000 psig 345 bar	5,000 psig 345 bar	1/4" NPT 1/4" NPT	30 Pa + Ps	50 psig (3.5 bar)	14.1
GBD-D30	6,000 psig 410 bar	9,000 psig 620 bar	1/4" NPT 1/4" NPT	60 Pa + Ps	200 psig (14 bar)	6.3
GBD-D75	6,000 psig 410 bar	25,000 psig 1,725 bar	9/16"-18 ⁽¹⁾ 9/16"-18 ⁽¹⁾	150 Pa + Ps	250 psig (17 bar)	2.4

- (1) Coned and Threaded High Pressure Connection for 1/4" O.D. Tubing.
2. Refer to corresponding gas booster performance curve for operating pressures (see page 9 to 20).
3. Maximum material rated outlet pressures can be reached under special operating conditions. Do not use air drive or/and gas supply pressures that equate to higher outlet pressures than those "maximum material rated outlet pressures" shown on table. Refer to Static Outlet Stall Pressure formula shown on table (for example, for gas booster model GBD-30 the formula is: Static Outlet Stall Pressure = 30*Pa+Ps).
4. Maximum recommended air drive operating pressure: 100-psi.
5. Maximum rated air drive pressure: 150-psi (only for static outlet stall pressure).
6. Maximum allowed working pressure for oxygen service boosters: 5,000-psi max.
7. Maximum allowed working pressure for hydrogen service boosters : 6,000-psi max.
8. Oxygen & hydrogen service boosters not available on all models. Contact factory for more information.



GBD-D SERIES

Double Acting-Double Head Booster

Legend
 PA = Drive Pressure
 PO = Gas Outlet Pressure
 PS = Gas Inlet Pressure
 VO = Output Gas Flow

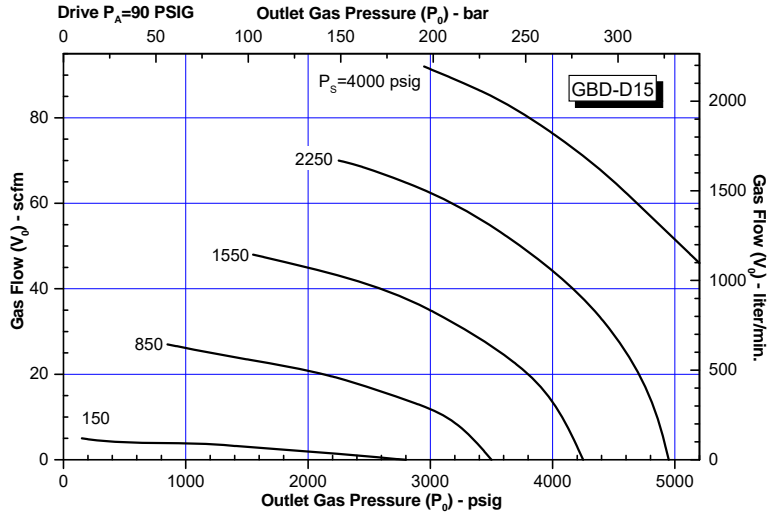

SS-GBD-D15

NOTE:
 Performance charts are for reference only.

The curves are based on an Air Drive (P_A) of 90 psig and a maximum air consumption of 72-scfm. If the P_A is higher or lower, the Outlet gas pressure (P_o) can change significantly.

Also, the supply pressures (P_s) shown in the graphs are based on constant pressure being supplied as the pressure is boosted. A supply from cylinders or bottles will affect the pressure outlet (P_o) and flow (V_o) as the supply pressure (P_s) is depleted.

Contact SC Hydraulic Engineering for detailed performance data on any

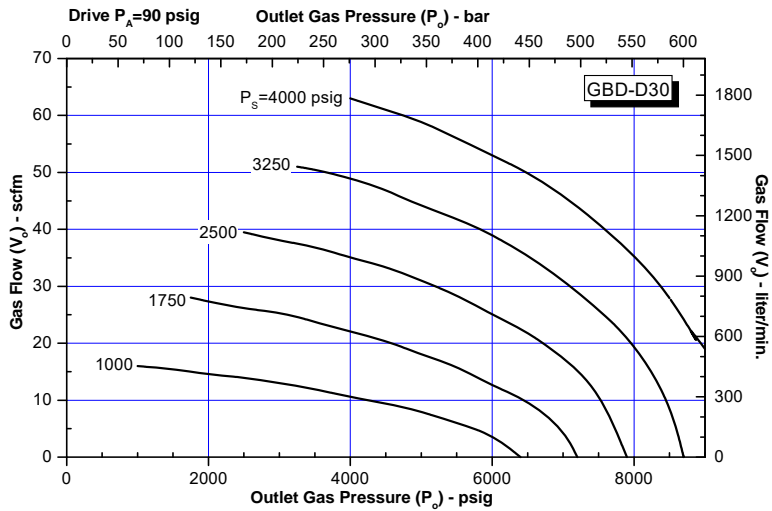

SS-GBD-D30

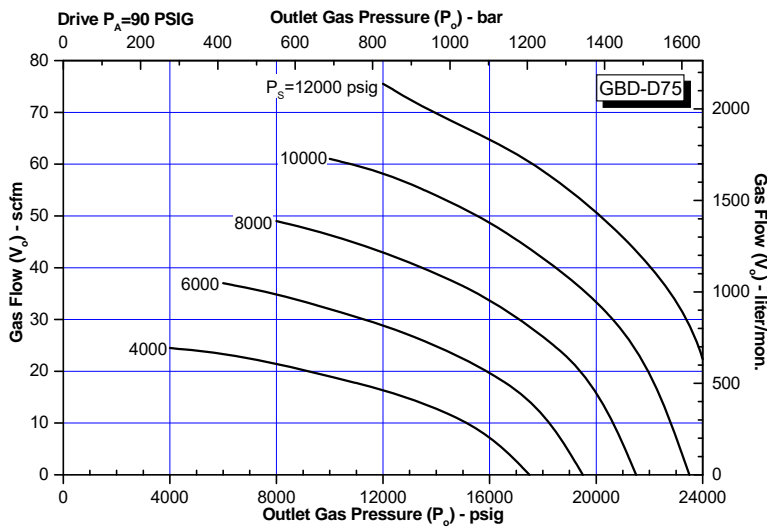

SS-GBD-D75

GBT SERIES

Two Stage-Double Acting Booster

The GBT series is able to achieve higher compression ratios by combining the first and second stage with an interconnected hydraulic (gas) piston. Maximum outlet pressure is the supply pressure plus the drive area ratio times the area ratio of both hydraulic (gas) pistons.

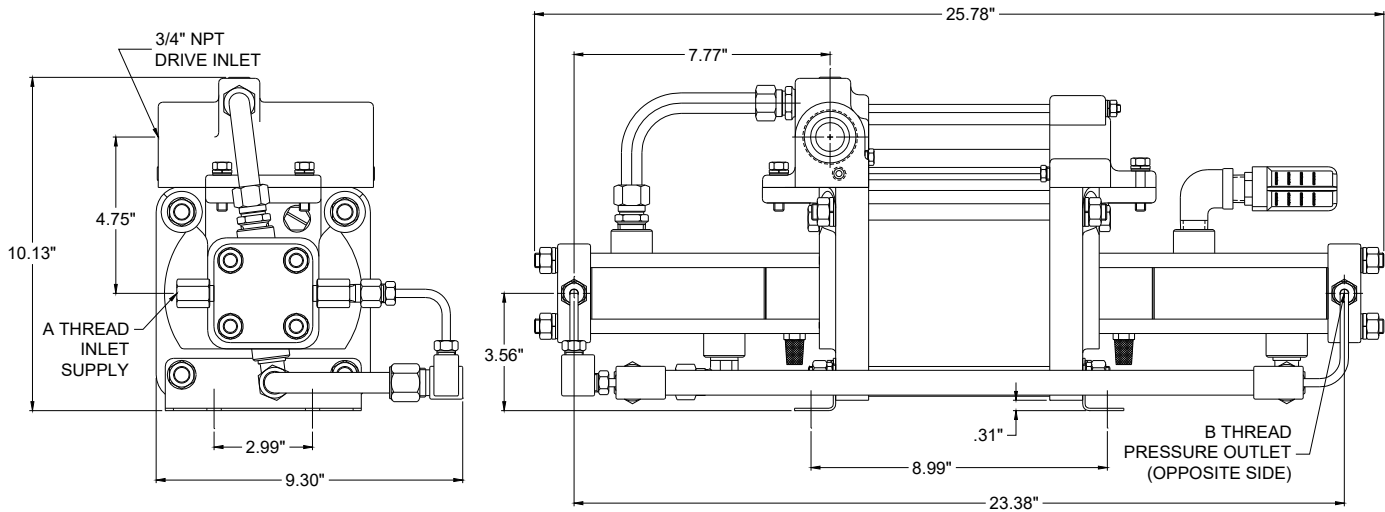

Model No.	Maximum Material Rated Gas Supply Pressure (Ps)	Maximum Material Rated Gas Outlet Pressure (Po)	Inlet Port (A) Outlet Port (B)	Static Outlet Stall Pressure	Minimum Inlet Gas Pressure (Ps)	Displacement Per Stroke (in ³ per cycle)
GBT-15/30	15 Pa to 2500 psig ⁽²⁾ 172 bar	9,000 psig 620 bar	1/4" NPT 1/4" NPT	30 Pa + 2 Ps	50 psig (3.5 bar)	7.05
GBT-15/75	3.5 Pa to 5000 psig ⁽²⁾ 345 bar	20,000 psig 1,380 bar	1/4" NPT 9/16"-18 ⁽¹⁾	75 Pa + 5 Ps	50 psig (3.5 bar)	7.05
GBT-30/75	20 Pa to 6000 psig ⁽²⁾ 410 bar	20,000 psig 1,380 bar	1/4" NPT 9/16"-18 ⁽¹⁾	75 Pa + 2.5 Ps	100 psig (7 bar)	3.1

(1) Coned and Threaded High Pressure Connection for 1/4" O.D. Tubing.

(2) GBT Series Gas Boosters: Limit maximum gas supply pressure by formula $P_s \text{ max} = \text{factor} * P_a$ to avoid interstage stall (for example, for gas booster model GBT-15/30 the formula is: $P_s \text{ max} = 15 * P_a$).

3. Refer to corresponding gas booster performance curve for operating pressures (see page 9 to 20).

4. Maximum material rated outlet pressures can be reached under special operating conditions. Do not use air drive or/and gas supply pressures that equate to higher outlet pressures than those "maximum material rated outlet pressures" shown on table. Refer to Static Outlet Stall Pressure formula shown on table (for example, for gas booster model GBD-30 the formula is: $\text{Static Outlet Stall Pressure} = 30 * P_a + P_s$).

5. Maximum recommended air drive operating pressure: 100-psi.

6. Maximum rated air drive pressure: 150-psi (only for static outlet stall pressure).

7. Maximum allowed working pressure for oxygen service boosters: 5,000-psi max.

8. Maximum allowed working pressure for hydrogen service boosters : 6,000-psi max.

9. Oxygen & hydrogen service boosters not available on all models. Contact factory for more information.

GBT SERIES

Two Stage-Double Acting Booster

Legend
 PA = Drive Pressure
 PO = Gas Outlet Pressure
 PS = Gas Inlet Pressure
 VO = Output Gas Flow

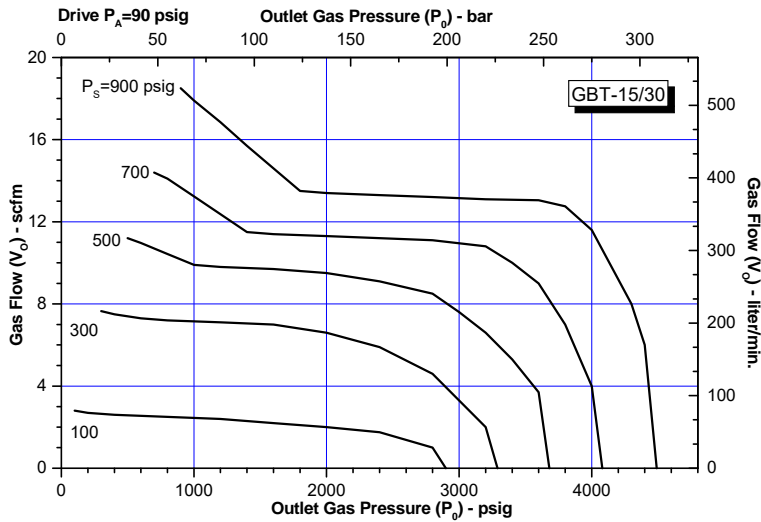

SS-GBT-15/30

NOTE:
 Performance charts are for reference only.

The curves are based on an Air Drive (P_A) of 90 psig and a maximum air consumption of 72-scfm. If the P_A is higher or lower, the Outlet gas pressure (P_o) can change significantly.

Also, the supply pressures (P_s) shown in the graphs are based on constant pressure being supplied as the pressure is boosted. A supply from cylinders or bottles will affect the pressure outlet (P_o) and flow (V_o) as the supply pressure (P_s) is depleted.

Contact SC Hydraulic Engineering for detailed performance data on any

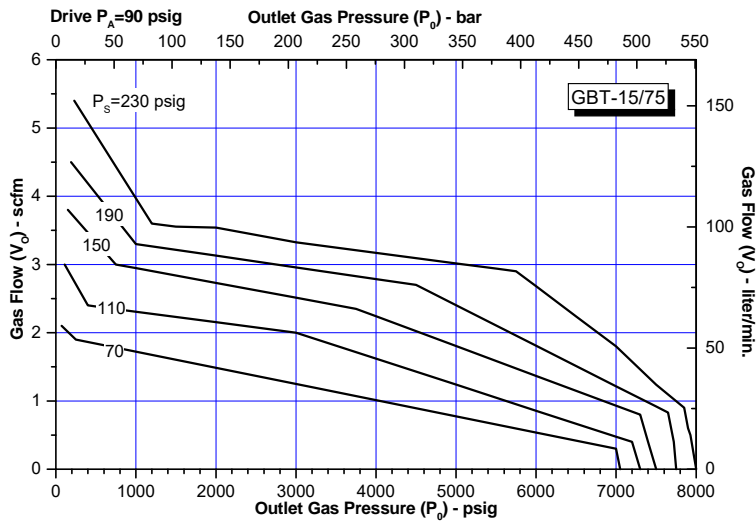

SS-GBT-15/75

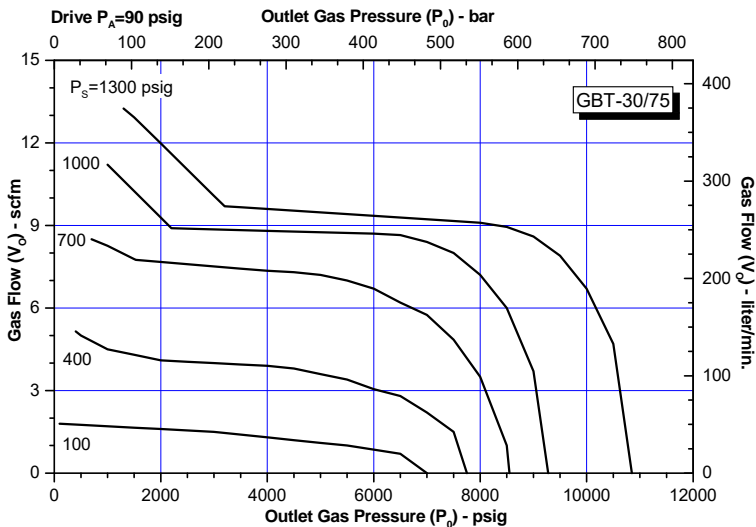

SS-GBT-30/75

GBT-D SERIES

Two Stage-Double Head Booster

This series has the same characteristics of the standard GBT however the double head allows half the input pressure to achieve the same outlet pressure.

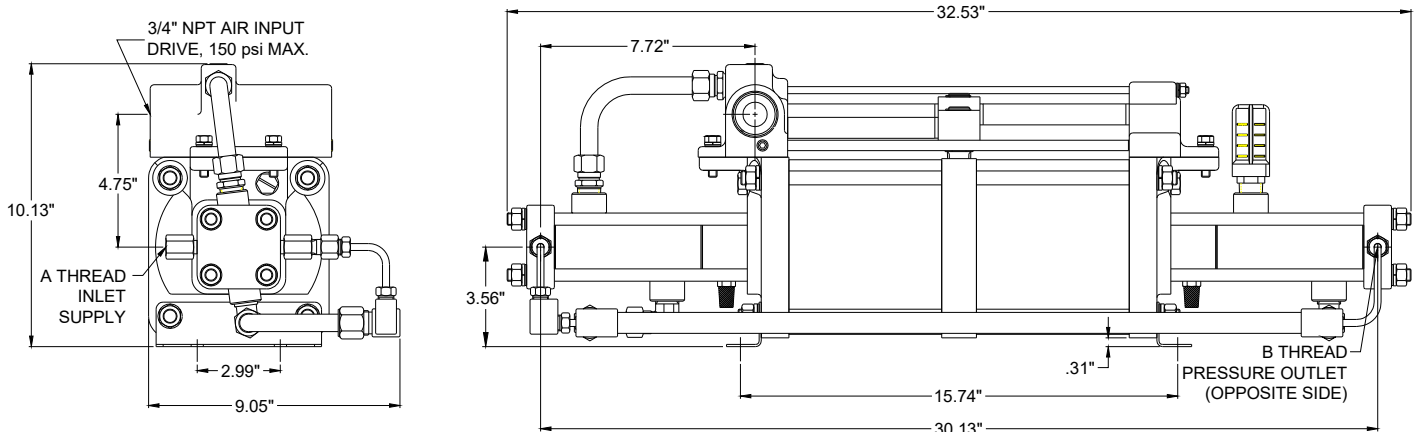

Model No.	Maximum Material Rated Gas Supply Pressure (Ps)	Maximum Material Rated Gas Outlet Pressure (Po)	Inlet Port (A) Outlet Port (B)	Static Outlet Stall Pressure	Minimum Inlet Gas Pressure (Ps)	Displacement Per Stroke (in3 per cycle)
GBT-D15/30	30 Pa to 2500 psi ⁽²⁾	9,000 psig 620 bar	1/4" NPT 1/4" NPT	60 Pa +2 Ps	100 psig (7 bar)	7.05
GBT-D15/75	7 Pa to 5000 psig ⁽²⁾	25,000 psig 1,725 bar	1/4" NPT 9/16"-18 ⁽¹⁾	150 Pa + 5 Ps	100 psig (7 bar)	7.05
GBT-D30/75	40 Pa to 3600 psig ⁽²⁾	25,000 psig 1,725 bar	1/4" NPT 9/16"-18 ⁽¹⁾	150 Pa + 2.5 Ps	100 psig (7 bar)	3.1

- (1) Coned and Threaded High Pressure Connection for 1/4" O.D. Tubing.
- (2) GBT Series Gas Boosters: Limit maximum gas supply pressure by formula $P_s \text{ max} = \text{factor} * P_a$ to avoid interstage stall (for example, for gas booster model GBT-15/30 the formula is: $P_s \text{ max} = 15 * P_a$).
3. Refer to corresponding gas booster performance curve for operating pressures (see page 9 to 20).
4. Maximum material rated outlet pressures can be reached under special operating conditions. Do not use air drive or/and gas supply pressures that equate to higher outlet pressures than those "maximum material rated outlet pressures" shown on table. Refer to Static Outlet Stall Pressure formula shown on table (for example, for gas booster model GBD-30 the formula is: $\text{Static Outlet Stall Pressure} = 30 * P_a + P_s$).
5. Maximum recommended air drive operating pressure: 100-psi.
6. Maximum rated air drive pressure: 150-psi (only for static outlet stall pressure).
7. Maximum allowed working pressure for oxygen service boosters: 5,000-psi max.
8. Maximum allowed working pressure for hydrogen service boosters : 6,000-psi max.
9. Oxygen & hydrogen service boosters not available on all models. Contact factory for more information.

GBT-D SERIES

Two Stage-Double Head Booster

Legend
 PA = Drive Pressure
 PO = Gas Outlet Pressure
 PS = Gas Inlet Pressure
 VO = Output Gas Flow

NOTE:

Performance charts are for reference only.

The curves are based on an Air Drive (Pa) of 90 psig and a maximum air consumption of 72-scfm. If the Pa is higher or lower, the Outlet gas pressure (Po) can change significantly.

Also, the supply pressures (Ps) shown in the graphs are based on constant pressure being supplied as the pressure is boosted. A supply from cylinders or bottles will affect the pressure outlet (Po) and flow (Vo) as the supply pressure (Ps) is depleted.

Contact SC Hydraulic Engineering for detailed performance data on any

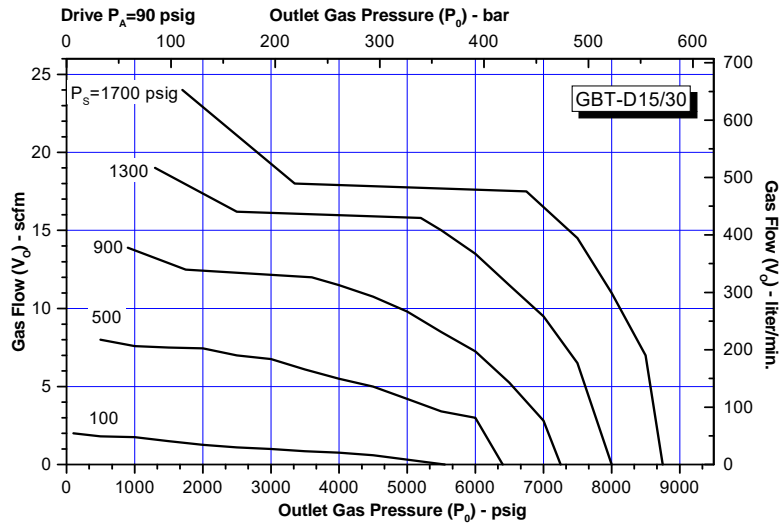

SS-GBT-D15/30

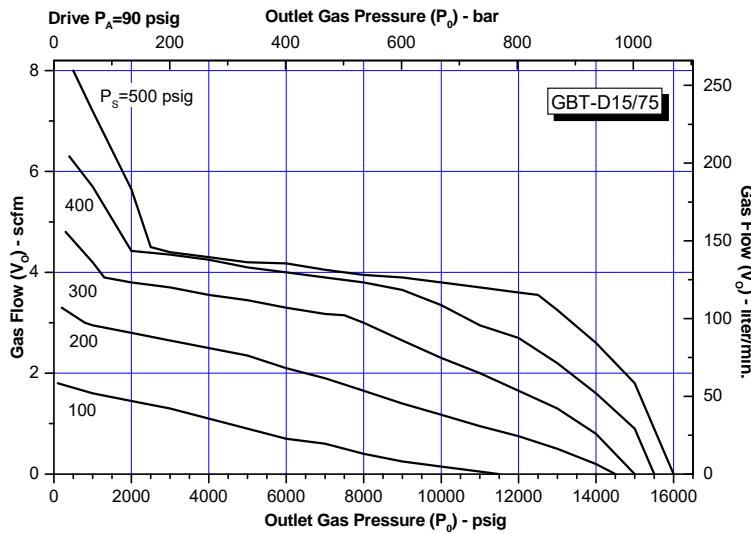

SS-GBT-D15/75

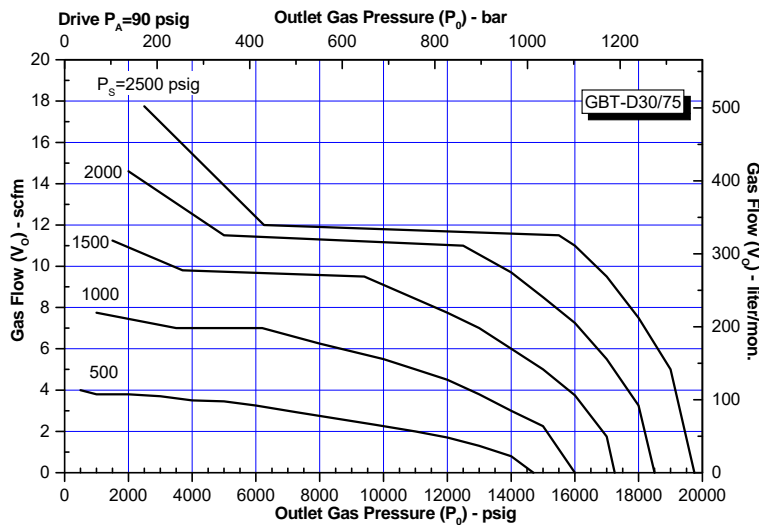

SS-GBT-D30/75

GAS BOOSTER

REFERENCE INFORMATION

(see performance curves for operating conditions)

Model No.	Maximum Material Rated Gas Supply Pressure (Ps)	Maximum Material Rated Gas Outlet Pressure (Po)	Inlet Port (A) Outlet Port (B)	Static Outlet Stall Pressure	Minimum Inlet Gas Pressure (Ps)	Displacement Per Stroke (in ³ per cycle)
GB-15	2,250 psig 155 bar	2,250 psig 155 bar	1/4" NPT 1/4" NPT	15 Pa	50 psi (3.5 bar)	7.05
GB-30	4,500 psig 310 bar	4,500 psig 310 bar	1/4" NPT 1/4" NPT	30 Pa	100 psig (7 bar)	3.1
GB-75	6,000 psig 410 bar	11,250 psig 775 bar	9/16"-18 ⁽¹⁾ 9/16"-18 ⁽¹⁾	75 Pa	250 psig (17 bar)	1.2
GB-D30	6,000 410 bar	9,000 620 bar	1/4" NPT 1/4" NPT	60 Pa	200 psig (13 bar)	3.1
GB-D75	6,000 410 bar	20,000 psig 1,380 bar	9/16"-18 ⁽¹⁾ 9/16"-18 ⁽¹⁾	150 Pa	250 psig (17 bar)	1.2
GBD-5	1500 psig 103 bar	1500 103 bar	1/2" NPT 1/2" NPT	4.7 Pa +Ps	25 psig	28.2
GBD-15	5,000 psig 345 bar	5,000 psig 345 bar	1/4" NPT 1/4" NPT	15 Pa + Ps	50 psi (3.5 bar)	14.1
GBD-30	6,000 psig 410 bar	9,000 psig 620 bar	1/4" NPT 1/4" NPT	30 Pa + Ps	100 psig (7 bar)	6.3
GBD-75	6,000 psig 410 bar	20,000 psig 1,380 bar	9/16"-18 ⁽¹⁾ 9/16"-18 ⁽¹⁾	75 Pa + Ps	250 psig (17 bar)	2.4
GBD-D15	5,000 psig 345 bar	5,000 psig 345 bar	1/4" NPT 1/4" NPT	30 Pa + Ps	50 psi (3.5 bar)	14.1
GBD-D30	6,000 psig 410 bar	9,000 psig 620 bar	1/4" NPT 1/4" NPT	60 Pa + Ps	200 psig (14 bar)	6.3
GBD-D75	6,000 psig 410 bar	25,000 psig 1,725 bar	9/16"-18 ⁽¹⁾ 9/16"-18 ⁽¹⁾	150 Pa + Ps	250 psig (17 bar)	2.4
GBT-15/30	15 Pa to 2500 psig ⁽²⁾	9,000 psig 620 bar	1/4" NPT 1/4" NPT	30 Pa +2 Ps	50 psi (3.5 bar)	7.05
GBT-15/75	3.5 Pa to 5000 psig ⁽²⁾	20,000 psig 1,380 bar	9/16"-18 ⁽¹⁾ 9/16"-18 ⁽¹⁾	75 Pa + 5 Ps	50 psi (3.5 bar)	7.05
GBT-30/75	20 Pa to 6000 psig ⁽²⁾	20,000 psig 1,380 bar	9/16"-18 ⁽¹⁾ 9/16"-18 ⁽¹⁾	75 Pa + 2.5 Ps	100 psig (7 bar)	3.1
GBT-D15/30	30 Pa to 2500 psig ⁽²⁾	9,000 psig 620 bar	1/4" NPT 1/4" NPT	60 Pa +2 Ps	100 psig (7 bar)	7.05
GBT-D15/75	7 Pa to 5000 psig ⁽²⁾	25,000 psig 1,725 bar	9/16"-18 ⁽¹⁾ 9/16"-18 ⁽¹⁾	150 Pa + 5 Ps	100 psig (7 bar)	6.3
GBT-D30/75	40 Pa to 3600 psig ⁽²⁾	25,000 psig 1,725 bar	9/16"-18 ⁽¹⁾ 9/16"-18 ⁽¹⁾	150 Pa + 2.5 Ps	100 psig (7 bar)	3.1

(1) Coned and Threaded High Pressure Connection for 1/4" O.D. Tubing.

(2) GBT Series Gas Boosters: Limit maximum gas supply pressure by formula $P_s \text{ max} = \text{factor} * P_a$ to avoid interstage stall (for example, for gas booster model GBT- 15/30 the formula is: $P_s \text{ max} = 15 * P_a$).

3. Refer to corresponding gas booster performance curve for operating pressures (see page 9 to 20).

4. Maximum material rated outlet pressures can be reached under special operating conditions. Do not use air drive or/and gas supply pressures that equate to higher outlet pressures than those "maximum material rated outlet pressures" shown on table. Refer to Static Outlet Stall Pressure formula shown on table (for example, for gas booster model GBD-30 the formula is: Static Outlet Stall Pressure = $30 * P_a + P_s$).

5. Maximum recommended air drive operating pressure: 100-psi.

6. Maximum rated air drive pressure: 150-psi (only for static outlet stall pressure).

7. Maximum allowed working pressure for oxygen service boosters: 5,000-psi max.

8. Maximum allowed working pressure for hydrogen service boosters : 6,000-psi max.

9. Oxygen & hydrogen service boosters not available on all models. Contact factory for more information.

Legend
Pa = Drive Pressure
Ps = Gas Inlet Pressure
Po = Gas Outlet Pressure

GAS BOOSTER SYSTEMS

Standard or Custom

SC Hydraulic Engineering Corporation builds every booster system like it's a custom unit built just for you. What separates us from other manufacturers is how fast we can ship you a complete system, whether it is considered a standard or in fact is a custom unit.

Our standard delivery for a complete system is one to two weeks, even quicker if you're willing to pay a nominal expedite fee. Better yet, a custom unit i.e. multiple boosters, extra ports, special valves, etc. is typically 3-4 week delivery. In most cases our deliveries are only extended if we have to wait for customer supplied add-on parts.



Our 3-4 week delivery for specials is about half the time other manufacturers' quote for a **standard** booster system!

We are able to do this because it is all we do. Our gas booster department builds only gas boosters and gas booster systems. The size of our company (we're proud of the fact we are not the largest) gives us the ability to be extremely flexible and work with each customer as an individual, not part of the herd.

Plus most of our manufactured parts are produced in house on state-of-the-art equipment. We are never dependent on some supplier's missed delivery, hence backing up all the orders in-house.

Our standard booster systems are built in three categories depending on the maximum outlet pressure a unit can deliver, 6K, 20K, or 25K PSI. Virtually any booster we manufacture can be used in a system.

Standard items on the booster are inlet air and gas supply filter, panel mounted air shut-off, regulator, air drive, gas supply and outlet gauges, and relief valve.

Bulkhead connections for air supply, gas supply and gas outlet are mounted on the side of the tubular frame. Standard frames are 38" or 45" long depending on the booster model.

Standard options are outlet filter, automatic start and/ or stop pilot switches, hydrogen, or oxygen service.



AIR PILOT SWITCH CODES

Air pilot switch valves can be used to automatically start and stop a gas booster system so that gas supplies are not depleted completely and/or the system stops at a predetermined pressure. When using an automatic start or stop a remote pilot must be specified on the gas booster. SC Hydraulic Engineering will preset the valves to your requirements if requested.

Use this chart to select the desired air pilot switch for your gas booster system if selected as an option.

Choose a normally closed N.C. for the automatic start and a normally open N.O. for the automatic stop.

Select the proper code from column three and add to the booster system model number.

SC Hydraulic Engineering will adjust the automatic start and/or stop at the factory.

AIR PILOT SWITCH VALVE SELECTION									
Model No.*	Type	System Order Code	Sensing Port		Adjustable Range (psig) Pressure setting at factory. Specify increasing/decreasing		Air Valves 150 psig Maximum Operating Pressure		Air Valve Configure Option
			Size	Max. Pressure	Normally Closed	Normally Open	Port Size	Cv Factor	
APS-100-01	A	01	1/4" NPT	15,000 psi O ₂ = 5,000	3,500-10,000	2,400-10,000	1/8" npt	.20 UP TO 11 SCFM	N.C. & N.O.
APS-070-02		02			1,400-7,000	940-6,400			
APS-051-03		03			800-5,100	700-4,600			
APS-013-04		04			340-1,300	260-1,200			
APS-148-05		05			3,500-14,800	2,500-12,000			
APS-100-06	B	06	1/4" NPT	15,000 psi O ₂ = 5,000	3,500-10,000		1/8" npt	.13 UP TO 7 SCFM	N.C.
APS-070-07		07			1,360-7,000				
APS-050-08		08			680-5,000				
APS-012-09		09			230-1,240				
APS-005-10	A	10	1/4" NPT	3,000 psi	170-550	125-510	1/8" npt	.20 UP TO 11 SCFM	N.O. & N.C.
APS-002-11		11			70-210	50-190			
APS-001-12		12			50-130	40-130			
APS-000-13		13			25-50	20-46			
APS-005-14	B	14	1/4" NPT	3,000 psi	145-520		1/8" npt	.13 UP TO 7 SCFM	N.C.
APS-002-15		15			55-210				
APS-001-16		16			30-135				
APS-000-17		17			15-45				
APS-200-18	A	18	HF4	20,000 psi	3,000-20,000	3,000-20,000		.20 UP TO 11 SCFM	N.O. & N.C.

LIMITED WARRANTY

SC manufactured products are warranted free of original defects in material and workmanship for a period of one year from date of purchase to first user. This warranty does not include packing, seals or failures caused by lack of proper maintenance, incompatible fluids, foreign materials in the air media, in the fluid media or application of pressures beyond catalog ratings. Products believed to be originally defective may be returned, freight prepaid, for repair and/or replacement to the distributor, authorized service representative or to the factory. If upon inspection by the factory or authorized service representative and the problem is found to be originally defective material or workmanship, repair or replacement will be made at no charge for labor and materials, F.O.B. the point of repair or replacement. Permission to return under warranty should be requested prior to shipment. A Return Material Authorization Number (RMA), the original purchase date, purchase order number, serial number, model number, reason for return or other pertinent data to establish warranty claim must be included in the documentation to expedite the return or replacement to the owner.

If the unit has been disassembled, misused, or altered without prior **written** authorization, warranty is void. If it has been improperly reassembled or substitute parts have been used in place of factory manufactured parts, warranty is void.

Any modification to any SC product which you have made or may make in the future will void warranty. SC disclaims any and all liability obligation, or responsibility for the modified product, and for any claims, demands or causes of action for damage or for personal injuries resulting from the modification and/or use of such a modified SC product.

SC's obligation with respect to its products shall be limited to replacement, and in no event shall SC be liable for any loss or damage, consequential or special, of whatever kind or nature, or any other expense which may arise in connection with or as a result of such products or the use or incorporation thereof in a job. This warranty is expressly made in lieu of all other warranties of merchantability and fitness for a particular purpose. No express warranty and no implied warranties whether of merchantability or fitness for a particular purpose or otherwise, other than those expressly set forth above, shall apply to SC products.