

TECHNICAL DATA SHEET

PRODUCT	HYDROSTATIC TEST EQUIPMENT
MODEL	CR-109REX
SERIES	SERIE CR-REX
API	CERTIFICATED ACCORDING TO THE API

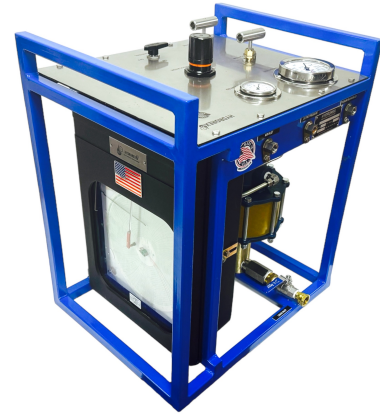

With pressure chart recorder air operated liquid system, lightweight portable, economic, safety, durable and easy to operate. Made in USA with highest quality components for low operational cost. CR-102REX equipment are available for use on a wide range of fluids including water, oil/hydraulic and other solubles. CR-102REX are used in most industries including Oil & Gas.

CR-REX Series are used in most industries including Oil & Gas for: Pressure on Pipes, Valves, Hoses, Vessels, Spools, etc.

FEATURES/BENEFITS

- Designed for easy maintenance
- Low cost servicing
- Air operated liquid pumps
- All pressure valves, tubing, fittings & hardware are stainless 316
- 12" Circular Pressure Chart Recorder
- Steel frame, Unit weight: 90 pounds - Dimensions: 22"L X 18" W 26"H
- HS Code: 8413.50.0050
- Certificated according to API specifications
- 24-56 SCFM

PERFORMANCE DATA

Output Flow	2.38 GPM (9 LPM)
Max Output Pressure	1000 psi (69 bar)
Air Supply - Driven	100 Psi
Air Inlet Port	1/2" female NPT
Inlet Liquid Port	1/2" female NPT
Outlet Pressure Port	1/2" female NPT
Pump Brand & Ration	SC-Hydraulic Ratio 10:1

FLOW CURVE RATIO 20:1

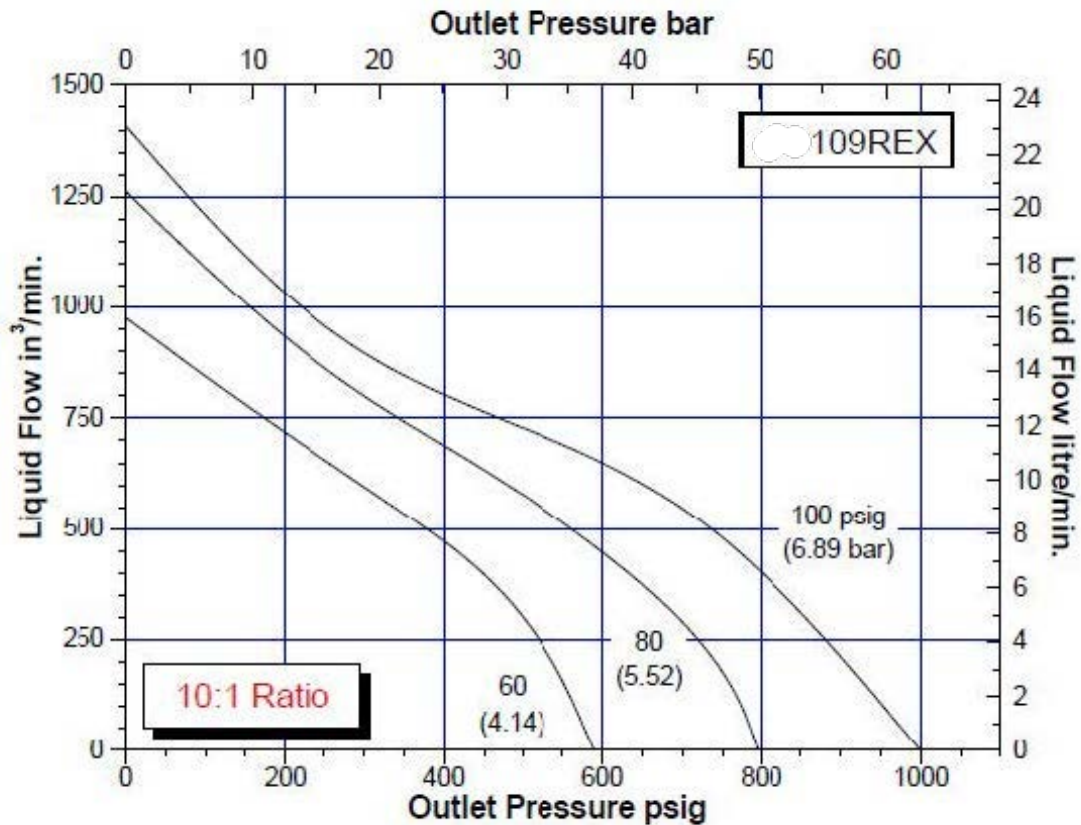

GENERAL PRODUCT INFORMATION

- When operating from 0 to rated hydraulic pressure, air consumption will be approximately **24-56 scfm** of free air at 100 psi output. At lower air pressures and higher hydraulic pressures air consumption will be reduced proportionately to flow rates indicated.
- The CR-REX Series "Dry Lube" pump does not require an air line lubricator.
- Contact Hydrorex for pressure gauges calibration / certificate.
- Maintenance parts for future repairs, all components & accessories can be found on our website www.hydrorex.com

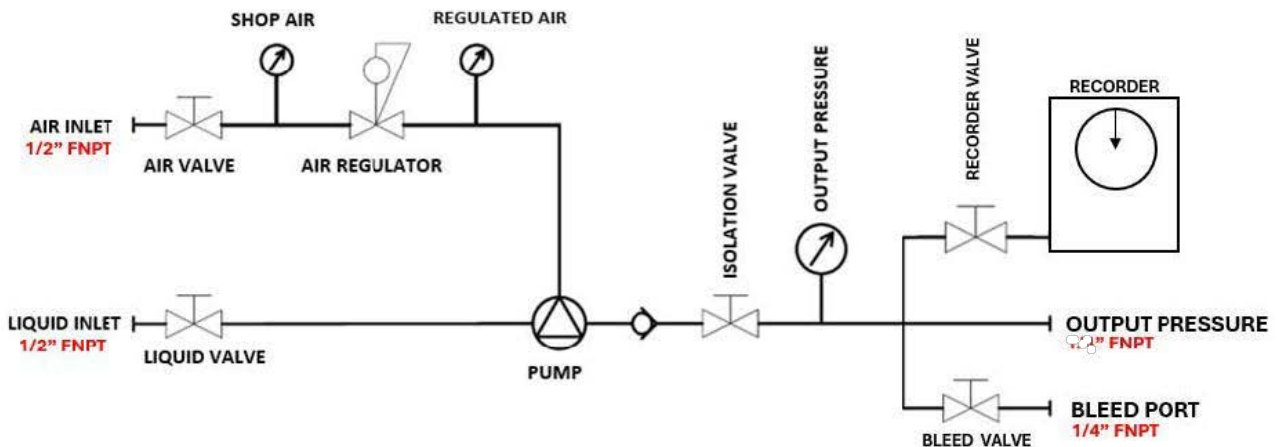

Quartz-USA / Chart Recorders Pressure & Temperature

Barton style chart recorders are the industry standard for accurate, reliable measurement and recording of pressure, differential pressure and temperature in a variety of applications

- Suitable for use on all hydro & industrial pressures.



Common Components

- **Case** - The case is made of rugged, lightweight die-cast aluminum that features a built-in rainshield. It is finished in polyurethane electrostatic powder paint that has a high resistance to weathering, scratches, and industrial fumes.
- **Recording Mechanism** - All parts are stainless steel for long life. The pen mount is exceptionally rugged and pen shafts are fitted with ball pivots to
- **Pressure Elements** - Are precision wound helical-type available pressure ranges up to 30,000 psi (up to 2068 bar).
- **Thermal Systems** - The systems consist of a bourdon tube, a capillary with stainless steel armor and a bulb with a bendable extension. All parts are stainless steel. Temperature ranges for each design are listed below. A thermal system must have a span of more than 50° F (27° C) and the high temperature limit must be greater than 95° F (35° C).
Standard (fully compensated)
-40° F to 600° F (-40° C to 315° C)

Mechanical Chart Recorders

Is a 12" chart recorder designed to measure flow, static pressure and temperature in all industrial pressure and ambient temperatures applications.

Is available in 1 to 2 or 3 pens configurations. The additional pens can be used to record temperature and supplemental pressure data.

More Common pressure ranges:

0-1000 PSI (70 BAR)

Static pressure measurements are provided by precision wound K-monel helical-type elements.

Main Components

