

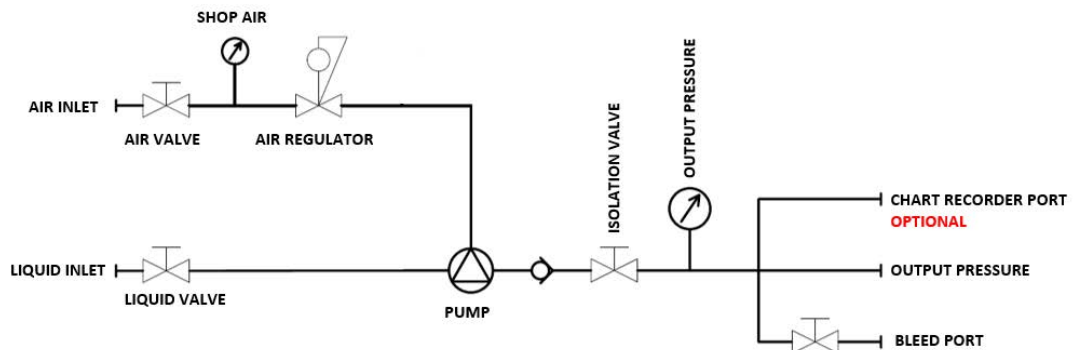

D1 REX SERIES HYDROSTATIC UNIT THE DOLLY CART STYLE

P
U
M
P
S



D1-REX SERIES

AIR PRESSURE GAUGE

AIR REGULATOR

OUTPUT PRESSURE

BLEED PRESSURE VALVE

ISOLATION VALVE

OUTPUT PRESSURE PORT



AIR PUMP VALVE

AIR INLET 1/2" FNPT

LIQUID INLET 1/2" FNPT

WITH GARDEN HOSE ADAPTER 3/4 GHT

SOLID RUBBER TIRES

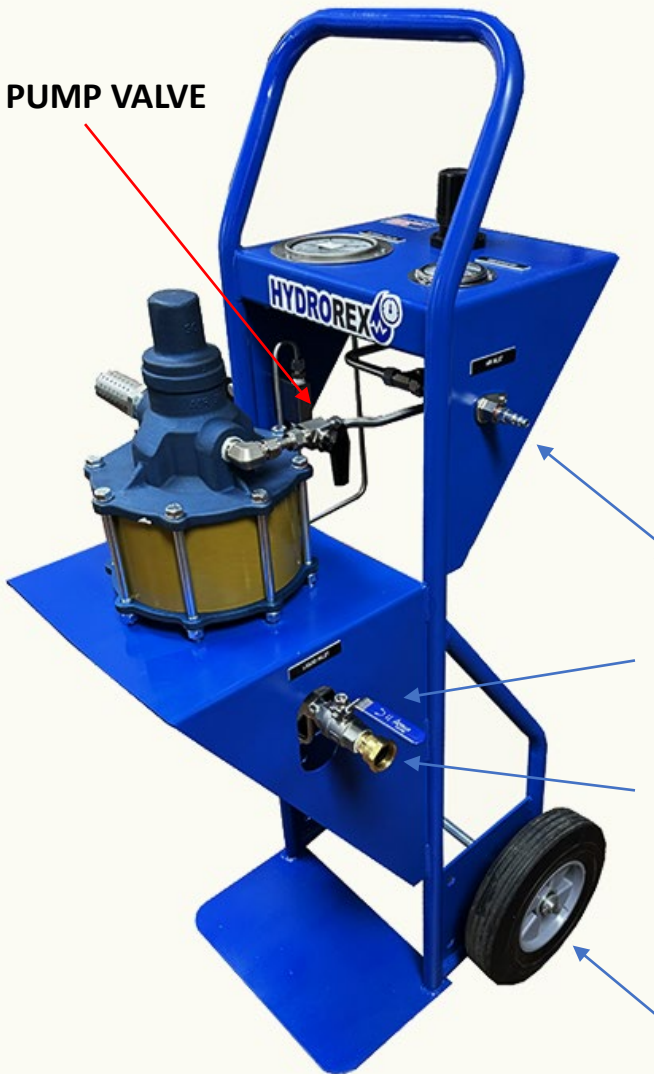

D1 REX SERIES

"The Dolly Cart Style" is the most common standard testing equipment.

LOW, MEDIUM & HIGH PRESSURE: Is a pneumatic drive system, twelve models are available with pressures up to 40,000 psig. Assembled into robust dolly frame, ideal for portable in the field. Designed for liquids pressures on all industries including Oil & Gas for use with any liquid such water, glycol, hydraulic, oils and more.

Made in USA with highest quality components for low operational cost.

When operating from 0 to rated hydraulic pressure, air consumption will be approximately 18-56 scfm of free air at 100 psi output. At lower air pressures and higher hydraulic pressures air consumption will be reduced proportionately to flow rates indicated.

The D1-REX Series "Dry Lube" pump does not require an air line lubricator

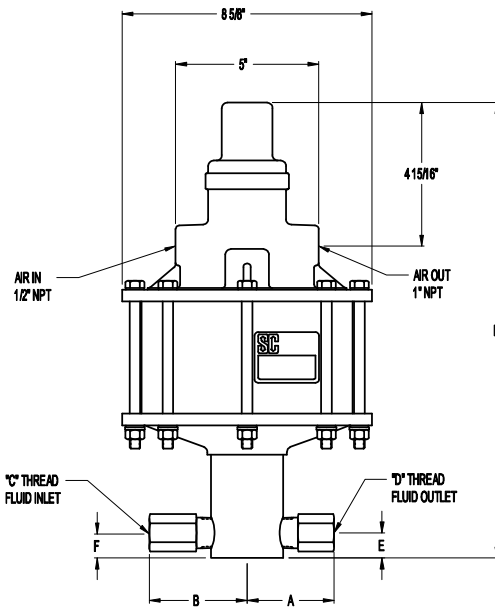

For pressure, flow rates and ports size for each model, please download the model datasheet below the product on the web www.hydrorex.com

Components: USA Brands, Parker, Quartz-USA, SC Hydraulic, Mc Daniels

- Structure: Heavy duty 1/8" carbon steel panels
- Assembled into robust dolly frame
- 1000 LBS Solid Rubber Tires.
- All Stainless steel, valves, tubing, fittings & hardware
- Requires 80 – 100 psi air pressure to operate

Dimensions: 20" Length, 46" High, 24" Width

Weight: 95 Lbs

Shipping Wood Crate Dimensions: 48"L x 24" H x 24" W

Shipping Weight: 130 Lbs

HS Code: 8413.50.50



Measurements & Approximate Air to Hydraulic Pressure

Pressure Ratio	D1 Series Model	Hydraulic Piston Diameter (in)	Hydraulic Piston Area (in ²)	Volume per Stroke (in ³)	Air Pressure (PSI)									
					10	20	30	40	50	60	70	80	90	100
5	D1-530	3.00	7.070	17.70	50	100	150	200	250	300	350	400	450	500
10	D1-1012	2.125	3.560	8.900	85	185	285	390	490	590	690	795	900	1000
20	D1-219	1.438	1.620	4.050	165	425	650	875	1075	1300	1550	1750	1950	2150
25	D1-277	1.315	1.350	3.380	180	450	725	1000	1300	1550	1850	2125	2400	2700
35	D1-365	1.125	0.994	2.490	250	625	1025	1400	1800	2150	2500	2850	3250	3600
55	D1-603	0.875	0.601	1.500	450	1050	1700	2275	2900	3500	4100	4650	5200	6000
95	D1-102	0.688	0.371	0.928	750	1750	2800	3700	4750	5900	6875	7700	8750	10000
145	D1-151	0.563	0.249	0.623	1100	2600	4200	5550	7100	8500	10000	11500	12950	14400
180	D1-181	0.500	0.196	0.490	1500	3200	5200	7100	9000	10800	12500	14500	16300	18000
240	D1-201	0.438	0.150	0.375	1900	4400	6900	9100	11600	14000	15400	17800	19300	20000
240	D1-251	0.438	0.150	0.375	1900	4400	6900	9100	11600	14000	16400	18800	21300	25000
330 **	D1-326 **	0.375	0.110	0.275	3000	6000	9500	12600	16000	19100	22300	25600	29000	32300



D1 REX SERIES

APPROXIMATE RATE OF DISCHARGE

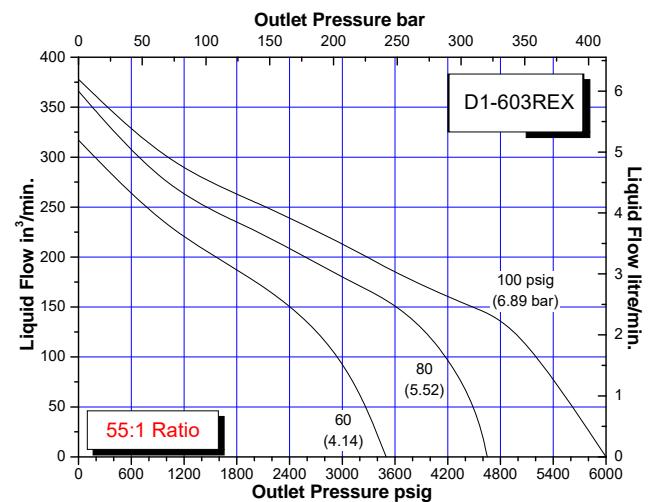
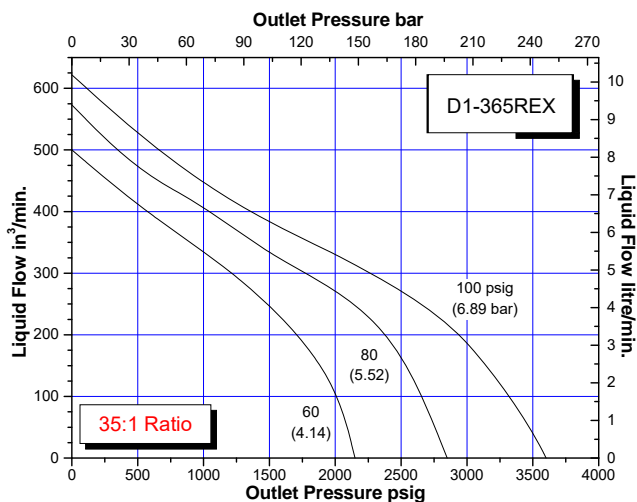
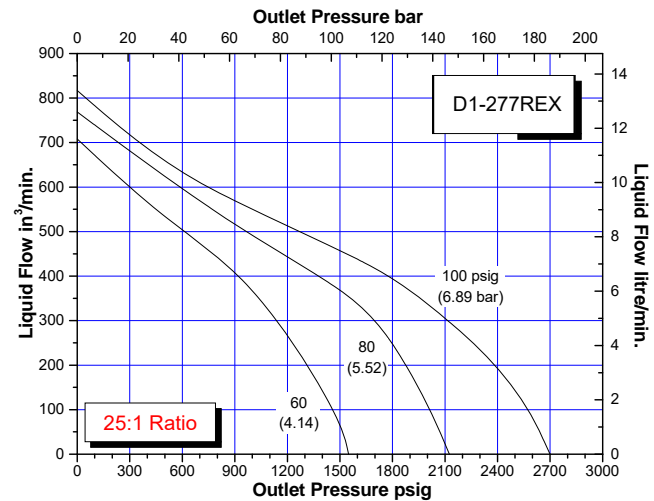
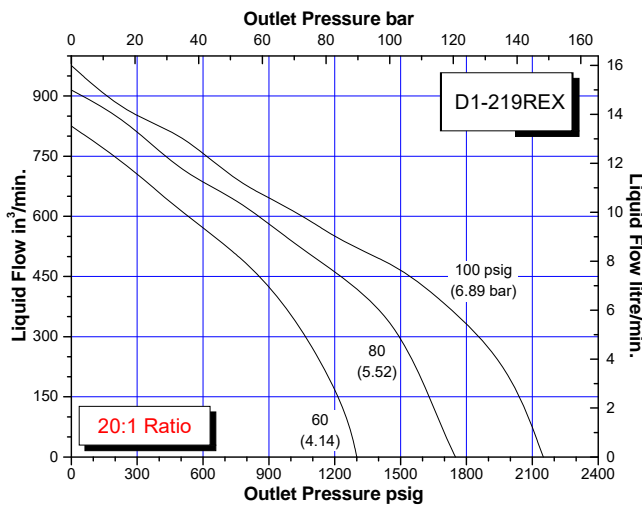
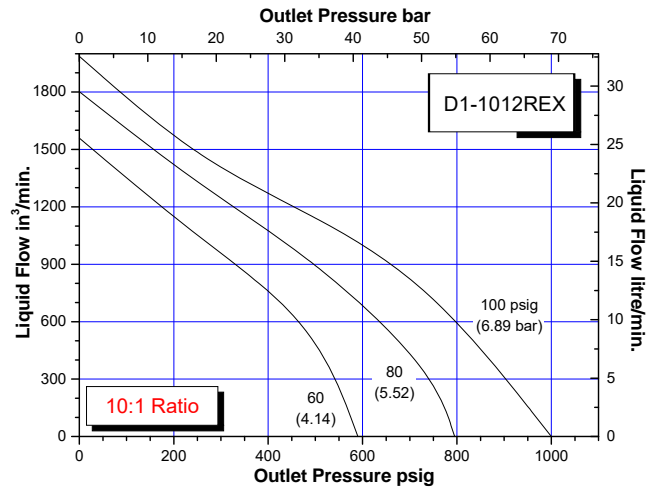
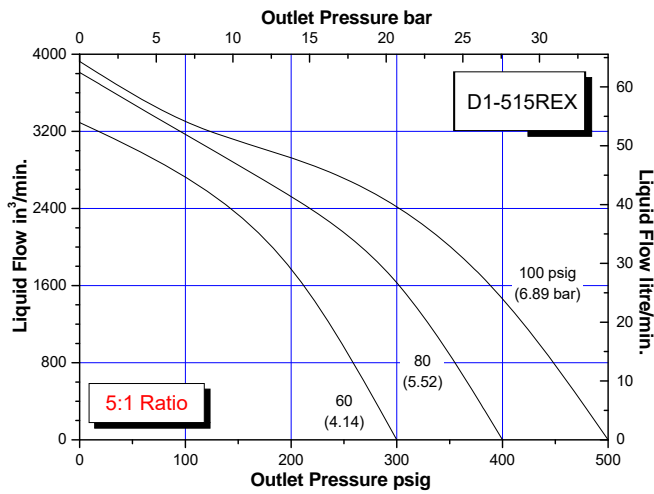

D1 REX SERIES

APPROXIMATE RATE OF DISCHARGE

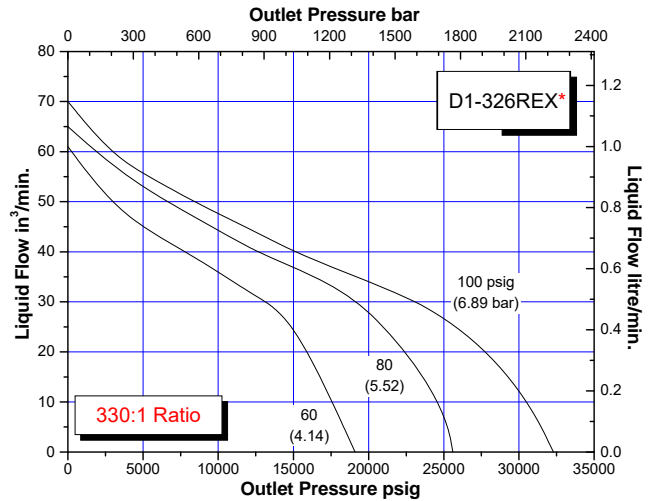
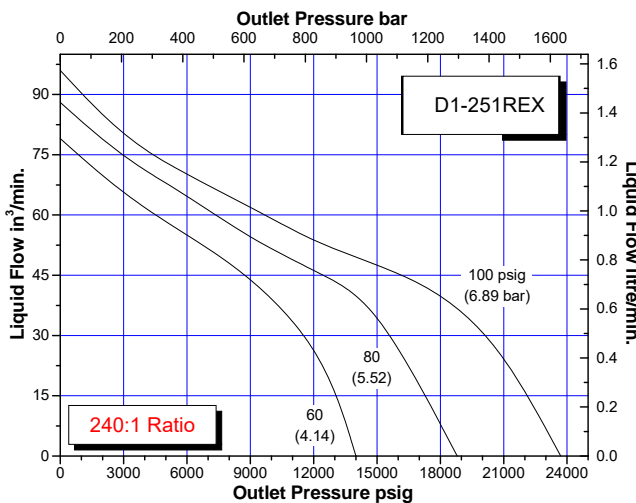
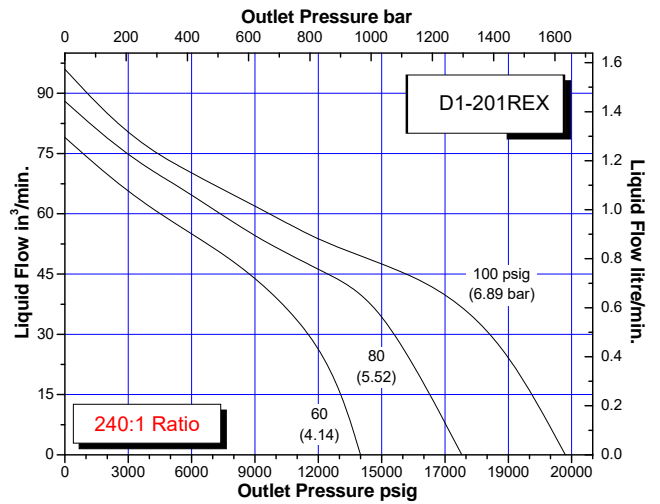
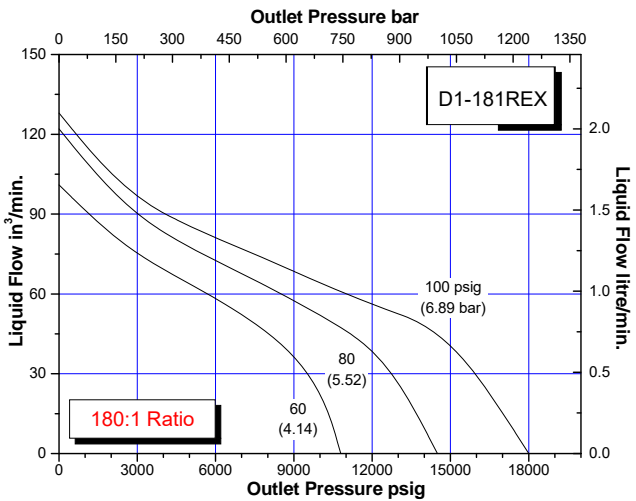
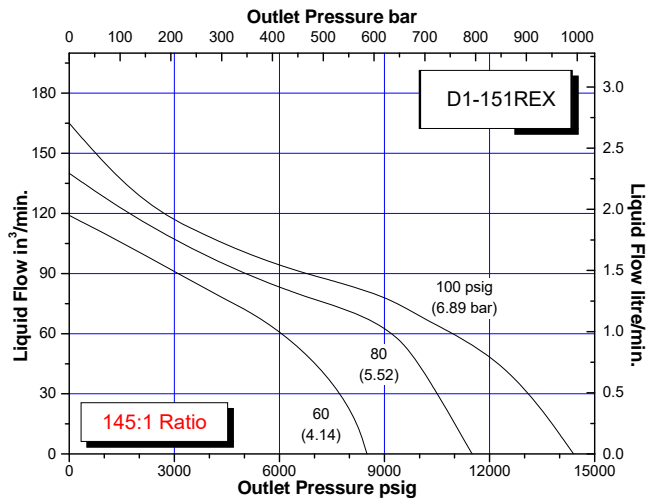
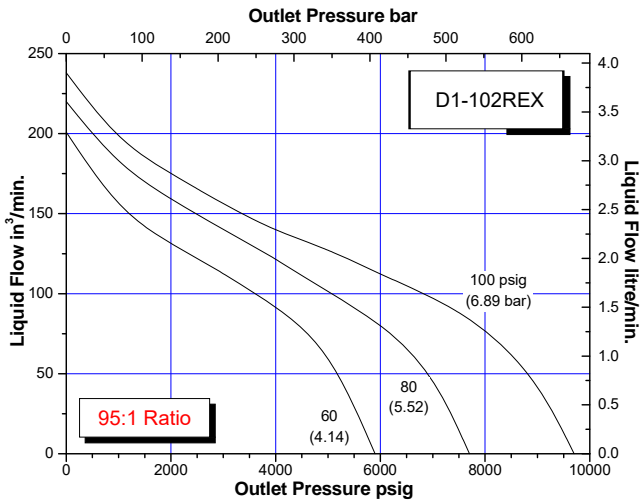

Liquid Pump Cut-a-way

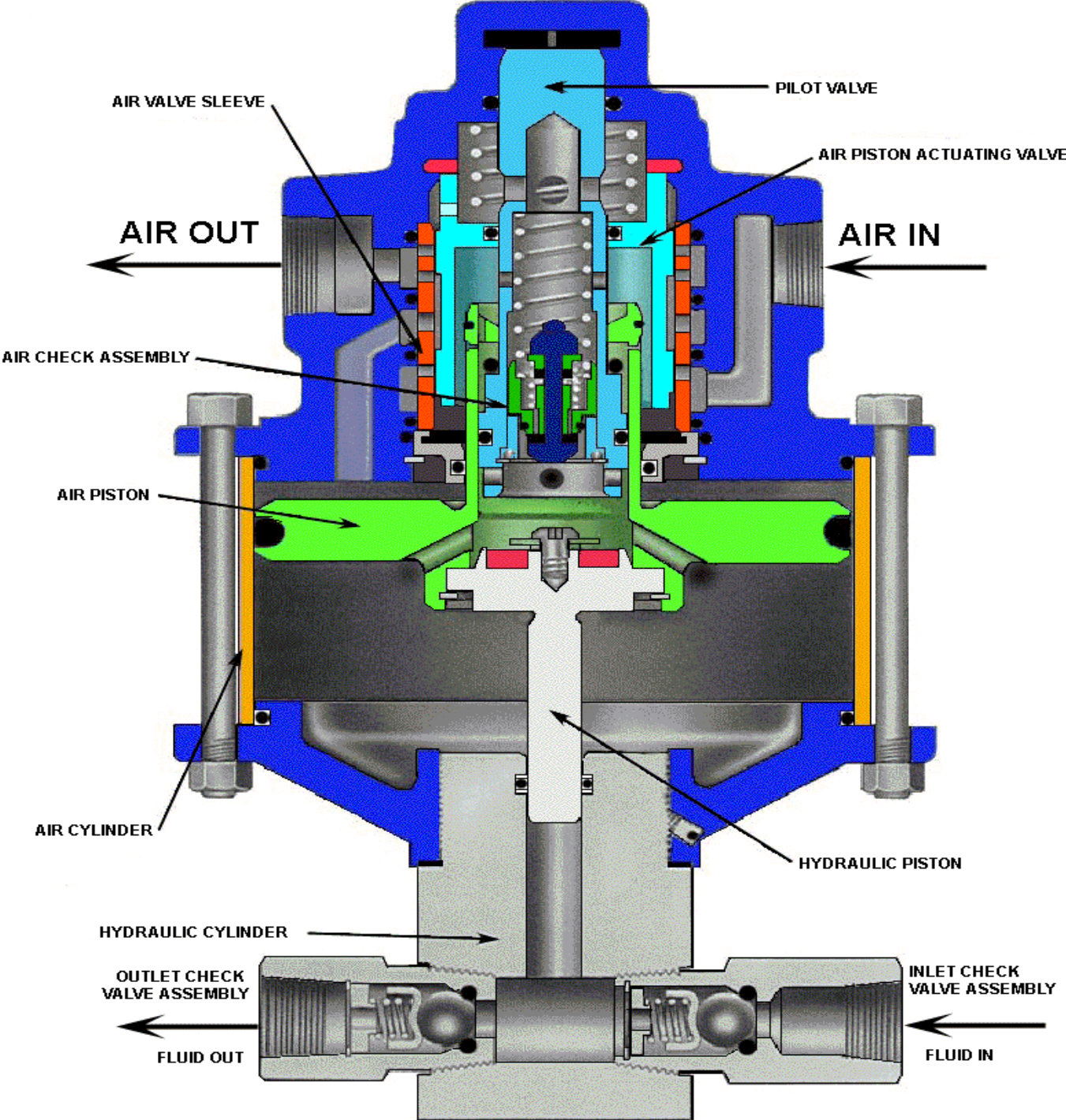

MANUFACTURER'S OPERATING INSTRUCTIONS

SERIES

• Serie D1-REX

PNEUMATIC HYDROSTATIC TEST PUMPS

Prior to testing any high pressure line, please check all connections, hoses and fittings to assure that they are properly tightened and in good working order. No frays, tears, or cuts.
REQUIRED: Air compressor capable of 80-100 PSI.

Liquids: Water, Hydraulic, Oils, Glycol and many more.



CONNECTING THE PUMP

1. Connect the output pressure hose provided. Position the Test Pump within 8 feet of test environment.
2. Connect the air line from the compressor to the inlet port on the combination regulator/air filter.

NOTE: AIR FILTER SHOULD BE DRAINED OF ANY WATER OR DIRT PARTICLES BEFORE, AND AFTER USE. Drain valve is located on the bottom of the filter body.

OPERATING THE PUMP

1. Open your liquid inlet ball valve
2. Open the return/bleed valve on the control panel or your test line to bleed off excess air.
NOTE: this should be done several times during test cycle.
3. Start your air shop compressor.
4. Once the compressor has reached operating pressure 100 psi (This will give maximum operating output) open the air ball valve slowly, which will allow the air to flow to the regulator.
5. Adjust the air regulator, Pull up on the black knob and turn clockwise to increase pressure, or counter-clockwise to decrease pressure. Once the inlet air pressure is set, push down on the knob to lock it in place.
6. Start turning regulator clockwise, pressure will begin building as soon as air flows. When desired test pressure has been met, close the outlet needle valve to isolate test environment. To turn off pump while testing, turn regulator counter clockwise and decrease or stop air flow, or disconnect air compressor supply. If a pressure drop is indicated, check the following:
 - a. Output hose connection at pump.
 - b. Output hose connection at test line.
 - c. Leaking test line or air in the test environment.
7. When you are done with the hydrostatic pressure test run, release the pressure open slowly the needle valve on control plate (bleed/return).

If the pressure gauge remains constant, turn off air ball valve and monitor gauge for your prescribed test time. When test is complete, open the high pressure return/bleeder valve located on control panel, Bleed off the liquid pressure. Repeat the above steps for multiple lines. Be sure the air pressure gauge reads zero before disconnecting the air line from the pump.