



Designers and Manufacturers of Hydraulic and Pneumatic Equipment

SC HYDRAULIC ENGINEERING CORPORATION

13360 Telge Rd #606 Cypress Texas USA - www.hydrorex.com

L10 SERIES AIR OPERATED DOUBLE-ACTING PUMPS

**P
U
M
P
S**



L10 SERIES

Double Acting Liquid Pump

APPLICATIONS

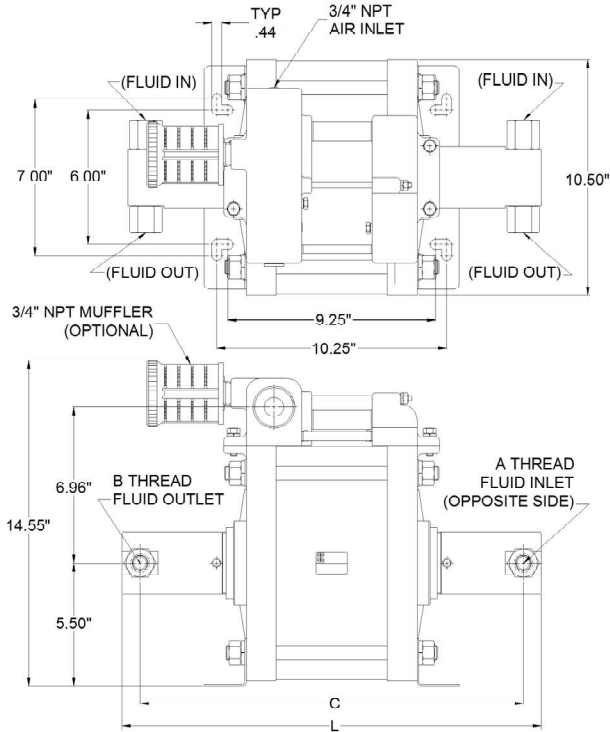

- Sub-sea valve actuation
- Safety shut down valves
- Wire-line control systems
- Blow-out preventer control systems
- Bolt tensioning
- Pressure testing
- Sub-surface control systems
- Flushing rigs

Mounting Dimensions in Inches

Dash Number	Pistons Area Ratio	Max. Outlet Pressure @ 100-psig Air Supply (PSI)	Displacement Per Cycle (Cu. In.)	Connection Ports NPT		C	L
				A Inlet	B Outlet		
-33	33	2,950	16.84	1"	1"	17.22	19.19
-66	64	6,000	8.59	1/2"	1/2"	17.10	18.70
-114	114	11,380	4.83	1/2"	1/2"	16.72	18.18
-177	178	17,700	3.09	1/2"	13/16-16*	17.14	18.61
-256	256	25,600	2.15	1/2"	1 1/8-12**	16.92	18.38

*Coned and Threaded Medium Pressure Connection for 20 KSI 9/16" O.D. Tubing.

**Coned and Threaded High Pressure Connection for 30 or 60 KSI 9/16" O.D. Tubing.

L10 SERIES

Double Acting Liquid Pump

L10-33

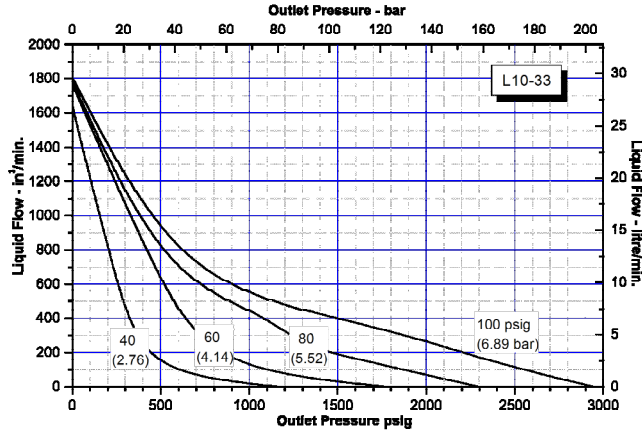

L10-66

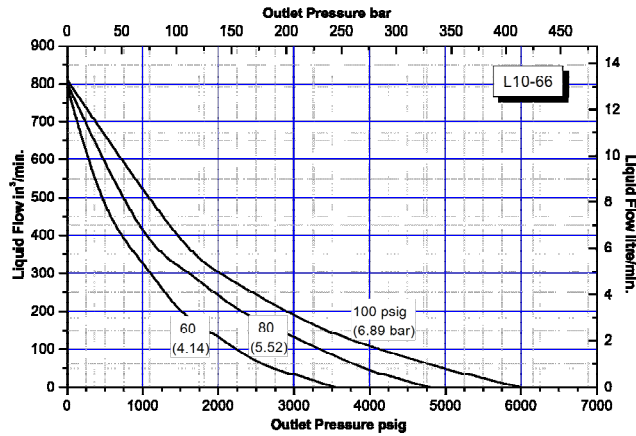

L10-114

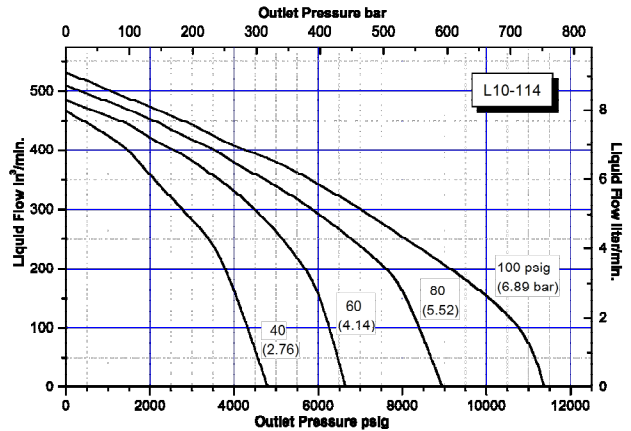

L10 SERIES

Double Acting Liquid Pump

L10-177

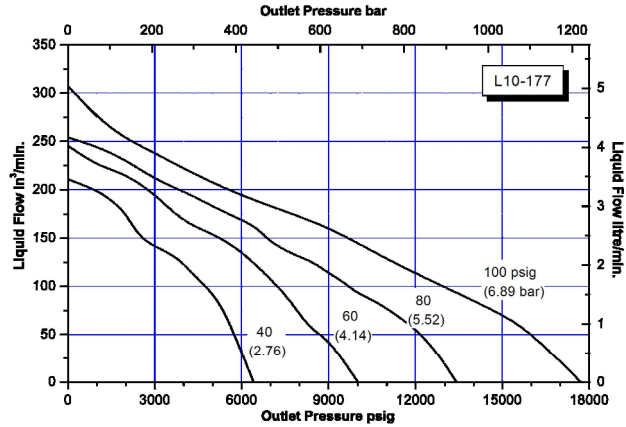

L10-256

