



AIR-OPERATED DOUBLE DIAPHRAGM PUMP

OWNER'S MANUAL



ITEM# 41763

 **WARNING:** Read carefully and understand all INSTRUCTIONS before operating. Failure to follow the safety rules and other basic safety precautions may result in serious personal injury.

Item#s41763 - Model TD12

This machine is designed for certain applications only. The distributor cannot be responsible for issues arising from modification. We strongly recommend this machine is not modified and/or used for any application other than that for which it was designed.

For technical questions, please call **1-800-222-5381**.

WARNING: Read carefully and understand all INSTRUCTIONS before operating. Failure to follow the safety rules and other basic safety precautions may result in serious personal injury. Save these instructions in a safe place and on hand so that they can be read when required. Keep these instructions to assist in future servicing.



INTRODUCTION

The diaphragm pump offers high volume delivery even at low air pressure.

Air-operated double diaphragm pumps utilize a pressure differential in the air chambers to alternately create suction and positive fluid pressure in the fluid chambers, ball check insure a positive flow of fluid.

Pump cycling will begin as air pressure is applied and it will continue to pump and keep up with the demand. It will build and maintain line pressure and will stop cycling once maximum line pressure is reached (dispensing device closed) and will resume pumping as needed.

TECHNICAL INFORMATION

Model	41763	
Inlet/Outlet	1/2"	
Air Inlet	1/4"	
Flow Rate	12GPM	
Max. Air Inlet Pressure	115PSI	
Max. Outlet Pressure	115PSI	
Max. Diameter Solid	1/8"	
Membrane	Nitrile	

DIMENSIONAL DATA (UNIT: MM)

MODEL: 41763 - TD-12GPM

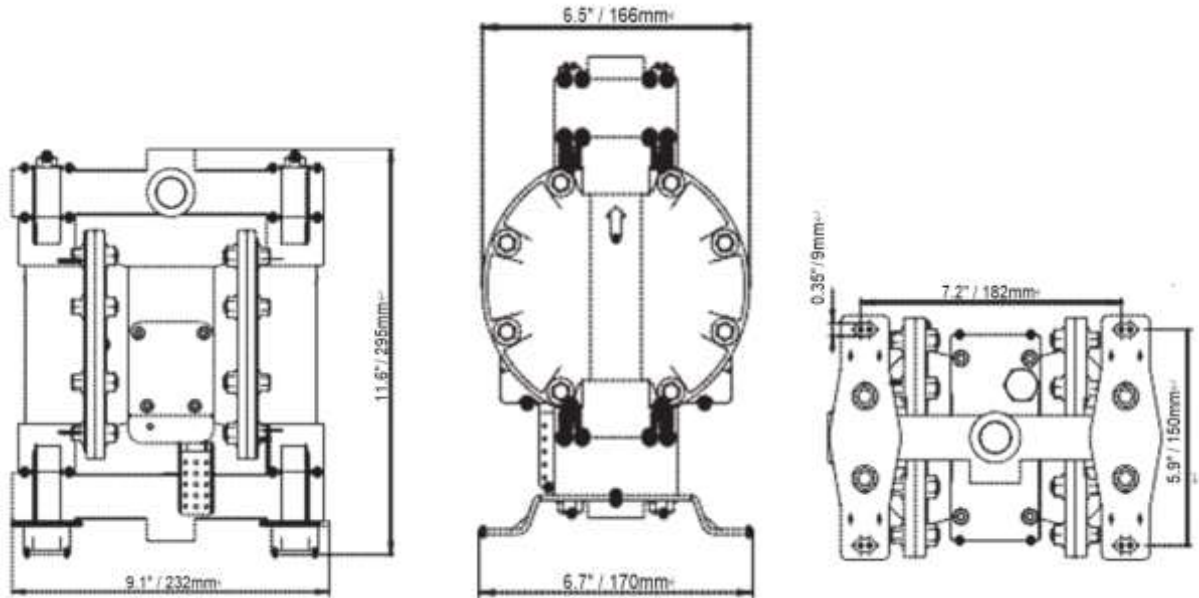

MODEL: 41769

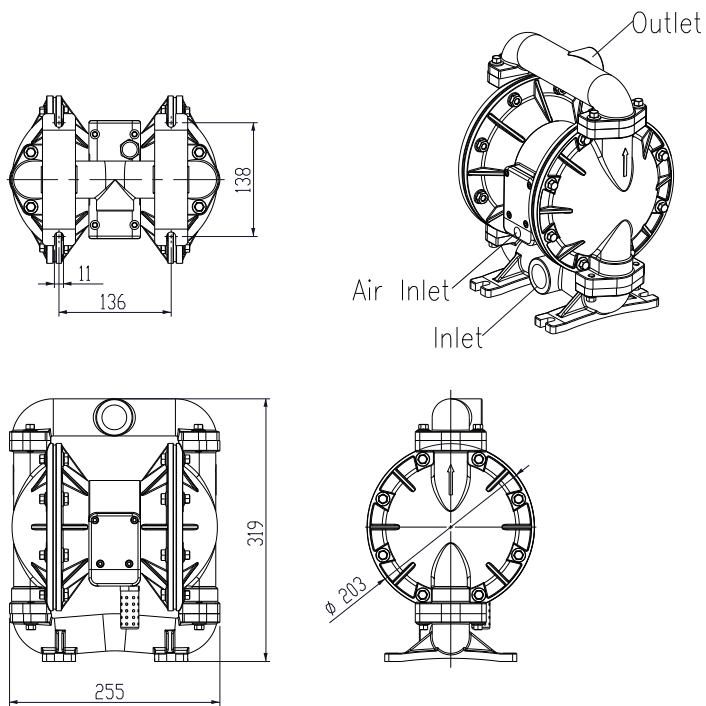

GENERAL SAFETY REGULATIONS

⚠ WARNING: Read and understand all instructions.

⚠ WARNING: The warnings, cautions, and instructions discussed in this instruction manual cannot cover all possible conditions or situations that could occur. It must be understood by the operator that common sense and caution are factors that cannot be built into this product, but must be supplied by the operator.

-
- 1. Keep the work area clean and dry.** Damp or wet work areas can result in injury.
 - 2. Keep children away from work area.** Do not allow children to handle this product.
 - 3. Store idle equipment.** When not in use, tools and equipment should be stored in a dry location to inhibit rust.
 - 4. Use the right tool for the job.** Do not attempt to force small equipment to do the work of larger industrial equipment. There are certain applications for which this equipment was designed. It will do the job better and more safely at the capacity for which it was intended. Do not modify this equipment, and do not use this equipment for a purpose for which it was not intended.
 - 5. Check for damaged parts.** Before using this product, carefully check that it will operate properly and perform its intended function. Check for damaged parts and any other conditions that may affect the operation of this product. Replace damaged or worn parts immediately.
 - 6. Do not overreach.** Keep proper footing and balance at all times to prevent tripping, falling, back injury, etc.
 - 7. DO NOT use the equipment when tired or under the influence of drugs, alcohol, or medication.** A moment of inattention while operating this equipment may result in serious personal injury.
 - 8. Industrial applications must follow OSHA requirements.**

SPECIFIC OPERATION WARNINGS

READ, UNDERSTAND, AND FOLLOW THIS INFORMATION TO AVOID INJURY AND PROPERTY DAMAGE.

⚠ WARNING! EXCESSIVE AIR PRESSURE CAN CAUSE PERSONAL INJURY, PUMP DAMAGE OR PROPERTY DAMAGE.

- Do not exceed the maximum inlet air pressure as stated on the pump model plate (115PSI).
- Be sure material hoses and other components are able to withstand fluid pressures developed by this pump. Check all hoses for damage or wear. Be certain dispensing device is clean and in proper working condition.

⚠ WARNING! STATIC SPARK CAN CAUSE EXPLOSION RESULTING IN SEVERE INJURY OR DEATH. GROUND PUMP AND PUMPING SYSTEM.

- Spark can ignite flammable material and vapors.
- The pumping system and object being sprayed must be grounded when it is pumping, flushing, recirculating or spraying flammable materials such as paints, solvents, lacquers etc. or used in a location where surrounding atmosphere is conducive to spontaneous combustion. Ground the dispensing valve or device, containers, hoses and any object to which material is being pumped.
- Use the pump grounding screw terminal provided. Connect a suitable ground wire to a good earth ground source.
- Secure pump, connections and all contact points to avoid vibration and generation of contact or static spark.
- Consult local building codes and electrical codes for specific grounding requirements.
- After grounding, periodically verify continuity of electrical path to ground. Test with an ohmmeter from each component (e.g., hoses, pump, clamps, container, spray gun, etc.) to ground to insure continuity. Ohmmeter should show 100 ohms or less.
- Use proper ventilation.
- Keep inflammables away from heat, open flames and sparks.
- Keep containers closed when not in use.

⚠ WARNING! Pump exhaust may contain contaminants, which can cause severe injury. Pipe exhaust away from work area and personnel.

-
- In the event of a diaphragm rupture material can be forced out of the air exhaust muffler.
 - Pipe the exhaust to a safe remote location when pumping hazardous or inflammable materials.
- ⚠ **WARNING! HAZARDOUS PRESSURE** can result in serious injury or property damage. Do not service or clean pump, hoses or dispensing valve while the system is pressurized.
- ⚠ **WARNING! EXPLOSION HAZARD.** Models containing aluminum wetted parts cannot be used with III.- Trichloroethane, Methylene Chloride or other Halogenated Hydrocarbon solvents which may react and explode.
- ⚠ **CAUTION!** Verify the chemical compatibility of the pump wetted parts and the substance being pumped, flushed or recirculated.
- ⚠ **CAUTION!** Do not use the pump for the structural support of the piping system. Be certain the system components are properly supported to prevent stress on the pump parts.
- ⚠ **CAUTION!** Prevent unnecessary damage to the pump. Do not allow pump to operate when out of material for long periods of time.
- Disconnect air line from pump when system sits idle for long periods of time.

OPERATING INSTRUCTIONS

AIR AND LUBE REQUIREMENTS

- ⚠ **WARNING! EXCESSIVE AIR PRESSURE CAN CAUSE PUMP DAMAGE, PERSONAL INJURY OR PROPERTY DAMAGE.**
- The air delivery pipe should be big enough to ensure the air needed.
 - Air pressure must not exceed 115 PSI (8 BAR).
 - A filter capable of filtering out particles larger than 50 microns should be used on the air supply. There is no lubrication required other than the O-ring lubricant which is applied during assembly or repair.
 - If lubricated air is present, make sure that is compatible with the O-rings in the air motor section of the pump.
1. Always flush the pump with a solvent compatible with the material being pumped if the material being pumped is subject to “setting up” when not in use for a period of time.
 2. Disconnect the air supply from the pump if it is to be inactive for a few hours.
 3. Disconnect the air supply from the pump if it is not in use.
 4. The material supply tubing should not be too small or restrictive. Be sure not to use hose which might collapse.
 5. When the diaphragm pump is used in a forced-feed (flooded inlet) situation, it is recommended that a “Check Valve” be installed at the air inlet.
 6. Secure the diaphragm pump legs to a suitable surface to insure against damage by vibration.

MAINTENANCE

- Provide a clean work surface to protect sensitive internal moving parts from contamination from dirt and foreign matter during service disassembly and reassembly.
- Keep good records of service activity and include pump in preventive maintenance program.
- Before disassembling, empty captured material in the outlet manifold by turning the pump upside down to drain material from the pump

TROUBLE SHOOTING

Product discharged from exhaust outlet.

- Check for diaphragm rupture
- Check tightness of diaphragm

Air bubbles in product discharge.

- Check connections of suction plumbing
- Check O-rings between intake manifold and fluid caps
- Check tightness of diaphragm nut

Low output volume, erratic flow, or no flow.

- Check air supply
- Check for plugged outlet hose
- Check for kinked (restrictive) or collapsed inlet material hose
- Check if there is leakage for the connection. These must be air tight
- Inspect the pump for solid objects logged in the diaphragm chamber or the seat area

DIAGRAMS AND PARTS LIST

1 FLUID SECTION FOR MODEL: 41763

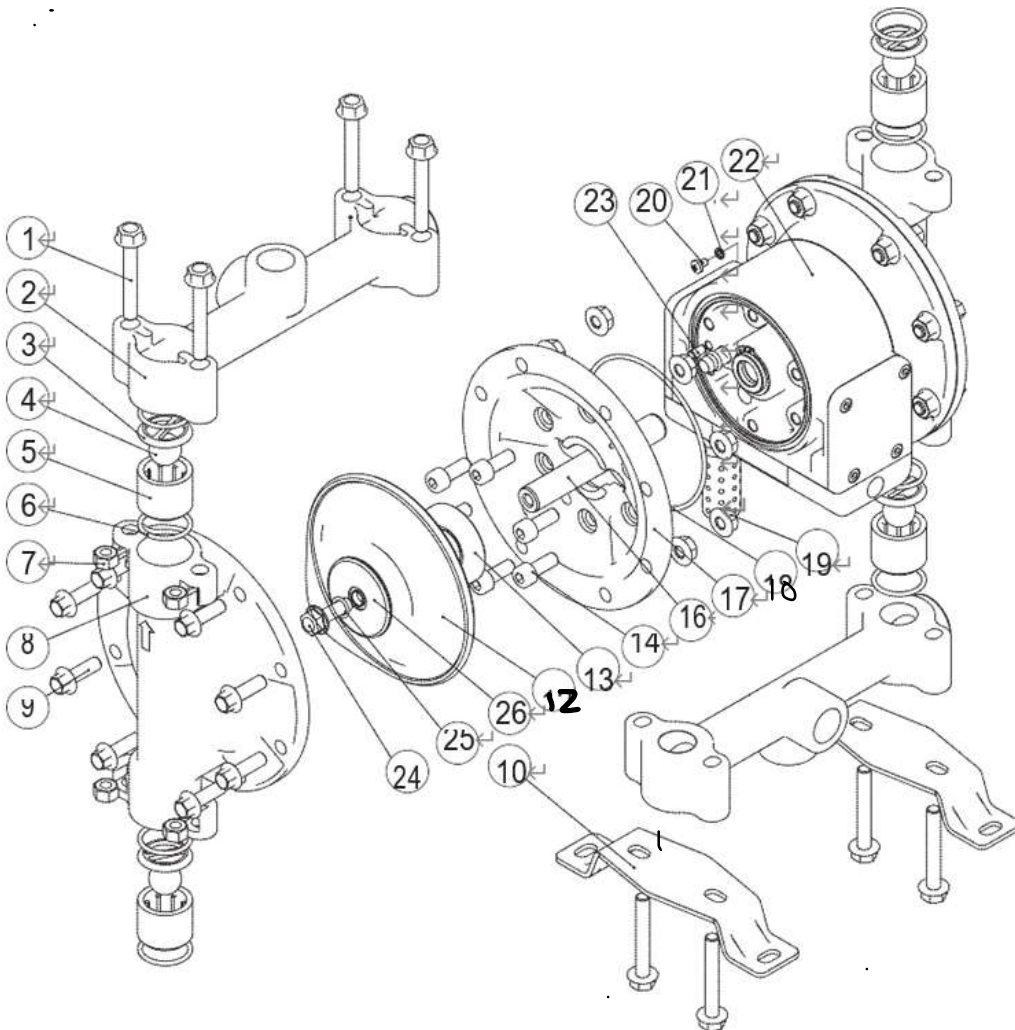

Part	Description	Q'ty	Part	Description	Q'ty
1	Hex-bolt M8x55	8	14	Screw M8X16	12
2	Discharge Manifold	2	16	Connecting Shaft	1
*3	Valve cover	4	17	Air Chamber	2
*4	Valve Ball	4	*18	O-ring 94.92X2.62	2
*5	Valve Seat	4	19	Hex-bolt M8	16
*6	O-ring 28.24x2.62	8	20	Screw M5X8	1
7	Nut M8	8	21	Washer	1
8	Liquid Chamber	2	22	Air Motor Assembly	1
9	Hex-bolt M8X25	16	23	Straight pin	2
10	Bracket	2	24	Hex-bolt M8x25	2
*12	Diaphragm	2	25	O-ring (9.75x1.78)	2
13	Air Chamber Plate	2	26	Liquid Chamber Plate	2

Note: The Part No. with "*" are the wearing parts.

2 AIR MOTOR SECTION

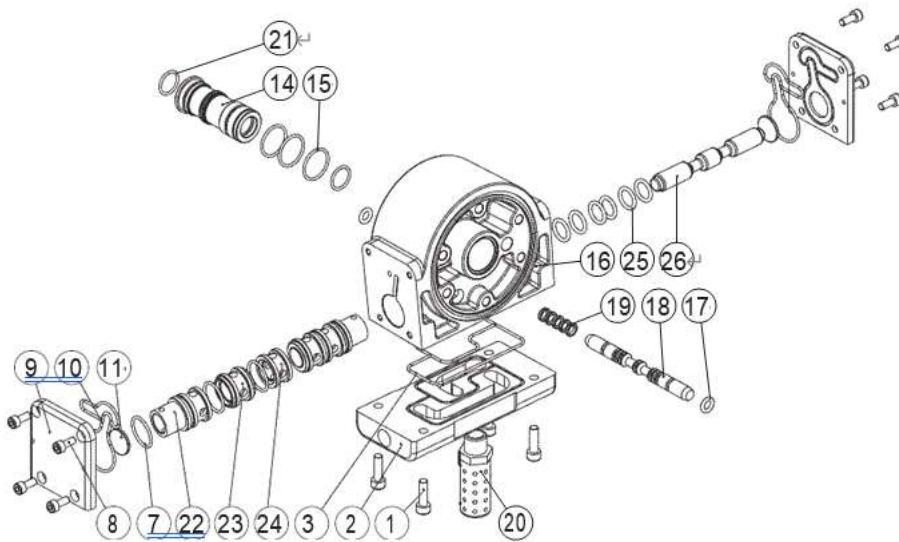

Part	Description	Q'ty	Part	Description	Q'ty
1	Hex-bolt M6X20	4	*17	O-ring 7.1X2.65	2
2	Press board	1	18	Pilot Valve	1
3	Seal for press board	1	*19	O-ring 6.86X1.78	5
*7	O-ring 13.94x2.62	6	20	Muffler 3/8"	1
8	Hex bolt M5X12	8	*21	O-ring 15.60X1.78	2
9	Gasket	2	22	Spacer	2
*10	Seal for gasket	2	23	Spacer	2
*11	Washer	2	24	Spacer	1
14	Sleeve	1	25	O-ring 13.94X2.62	6
*15	O-ring 20.35X1.78	3	26	Major Valve	1
16	Retaining Ring 25	1			

Note: The Part No. with "*" are the wearing parts.

For replacement parts and technical questions, please call **1-800-222-5381**.

WARRANTY

One-Year Limited Warranty



Distributed by
Northern Tool + Equipment Co.,
Inc. Burnsville, MN 55306 NC