

sales@hydrorex.com -
eli@hydrorex.com Office: 832 277
1182 - Mobil: 281 989 1216

13360 TELGE RD #606 CYPRESS
TEXAS 77429 USA



HYDROSTATIC
ENGINEERING



CUSTOM YOUR TEST CART

Based on Your Ideas or Needs!

Provide us with your engineering drawings and P&ID of your high pressure system, and we will integrate it according to your requirements, we have the supply of all types of high pressure coned and thread tubing, valves, gauges, fittings, hoses, adapters and all the necessary equipment.



P
U
M
P
S

www.hydrorex.com
www.pressureshop.com

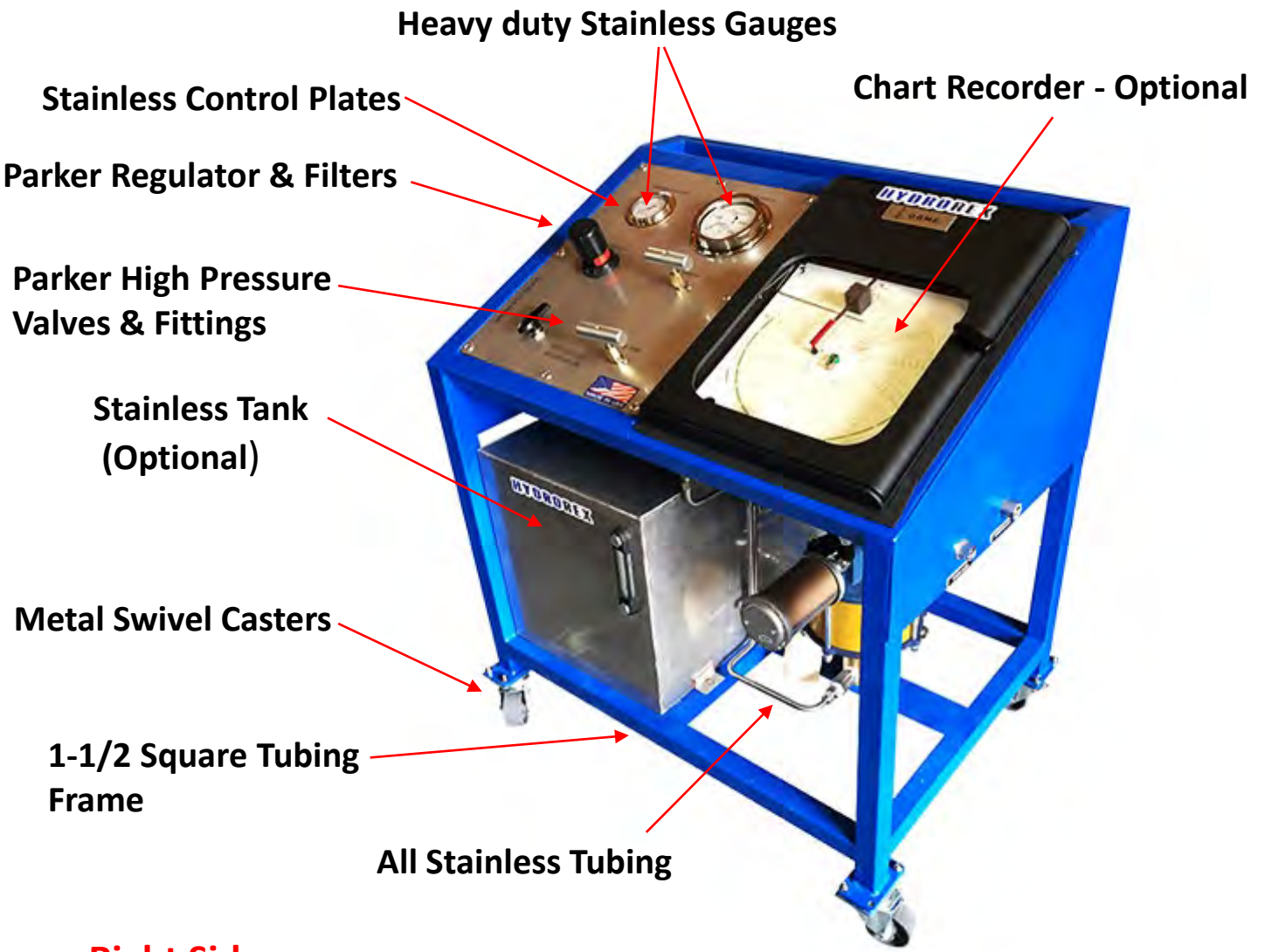

Right Side

Left Side

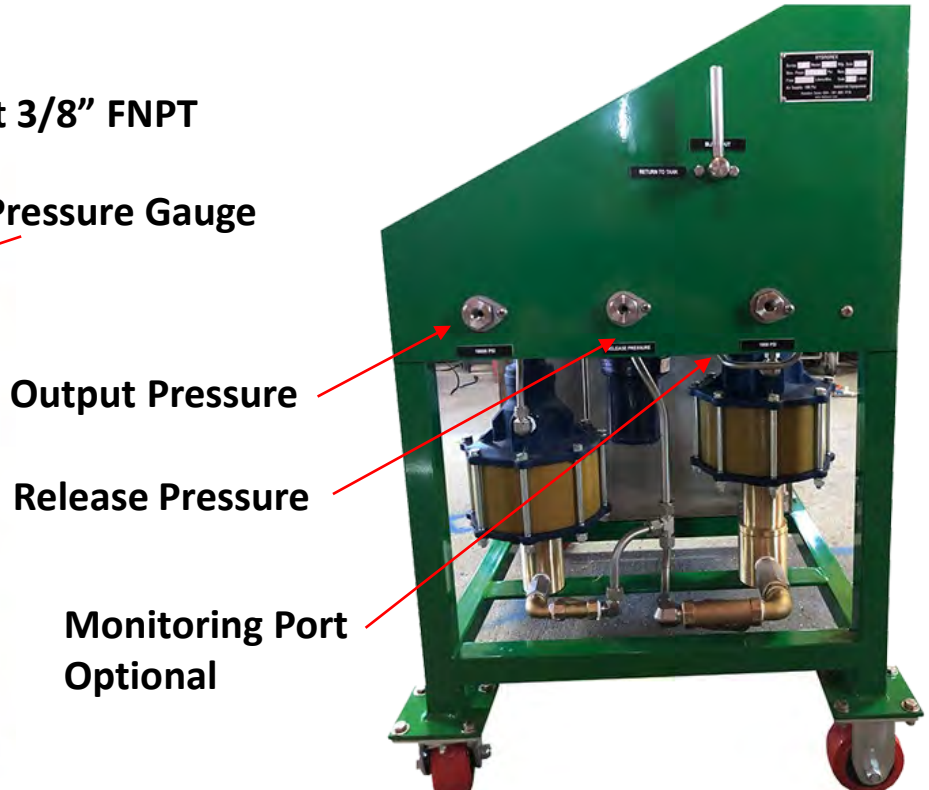

TC REX SERIES



“The Professional Style” is the most common standard testing equipment.

Contact us to custom build your own pressure system test cart or any other portable or stable unit based on your ideas or needs to meet your specific test requirement for **hydro, pressure static, burst, nitrogen booster, flushing, calibration, injection and more.**

LOW, MEDIUM & HIGH PRESSURE: Is a pneumatic drive systems, wide ranges of pressures and flows are available with pressures up to 65,000 psig. ideal for testing in small confined spaces and remote locations. Designed for liquids pressure on all industries including Oil & Gas for use with any liquid such water, glycol, hydraulic, oils and more.

Made in USA with highest quality components for low operational cost.

Components: USA Brands, Parker, Swagelok, SC Hydraulic, Mc Daniels

OUR TEST CART STANDARD INCLUDED

- Structure: Heavy duty 1-1/2" Square tubing carbon steel
- Stainless Steel control plates
- All Stainless steel, valves, tubing, fittings & hardware
- Metal casters - swivels
- Color: Industrial patriotic blue color
- Requires 90 – 120 psi air pressure to operate

Dimensions: 32" Length, 33" High, 24" Width

Weight: Approx. 180 Lbs

Shipping Package Dimensions: 38"L x 38" H x 30" W

Shipping Weight: Approx 220 Lbs

HS Code: 8413.50.50

Some Options of Custom

Metal Frame

- Stainless steel metal frame
- Metal casters
- Stainless steel control plates
- Pressure safety covers (front & sides)
- Stainless liquid tank (Max. 22 Gallons)
- Test Chamber
- Custom color / powder paint

Some of Many System Options

- Single pump
- Dual pumps - Air driven
- Dual system for High and
- Low Mechanical chart recorder
- Digital chart recorder
- Digital pressure gauges
- Liquid tank
- Test manifolds
- Extra outputs pressure
- PSV -Pressure safety valves
- Electrical motor pump
- Liquid or Nitrogen pumps



OPTIONS PUMPS AVAILABLE



Air driven liquid pumps thirteen models are available with pressures up to 65,000 psig for use with any liquid such water, glycol, hydraulics, oils and more.

When operating from 0 to rated hydraulic pressure, air consumption will be approximately 18-56 scfm of free air at 100 psi output. At lower air pressures and higher hydraulic pressures air consumption will be reduced proportionately to flow rates indicated.

10 Series pumps have a 7" diameter air piston and a 2 1/2" stroke.

The 10-6 Series "Dry Lube" pump does not require an air line lubricator

HIGH OUTPUT CAPACITY
 GUARANTEED PERFORMANCE
 MULTIPLE OUTPUT CAPACITIES
 SIMPLE OPERATION PRINCIPLE
 DESIGNED FOR EASY MAINTENANCE
 WIDE RANGE OF OPERATING PRESSURES

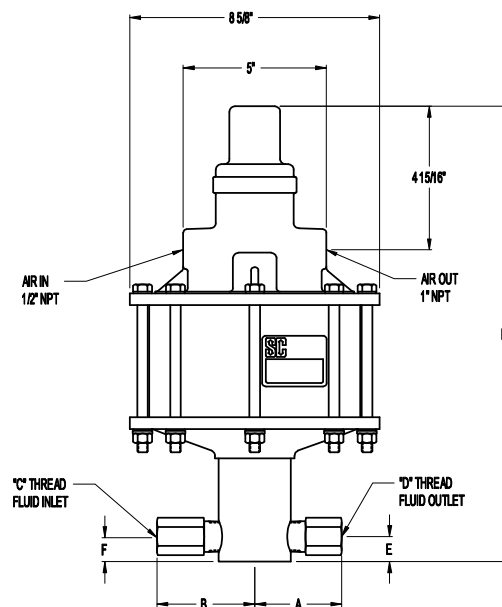

Measurements & Approximate Air to Hydraulic Pressure

Pressure Ratio	PUMPS Model	Hydraulic Piston Diameter (in)	Hydraulic Piston Area (in ²)	Volume per Stroke (in ³)	Air Pressure (PSI)									
					10	20	30	40	50	60	70	80	90	100
5	530	3.00	7.070	17.70	50	100	150	200	250	300	350	400	450	500
10	1012	2.125	3.560	8.900	85	185	285	390	490	590	690	795	900	1000
20	219	1.438	1.620	4.050	165	425	650	875	1075	1300	1550	1750	1950	2150
25	277	1.315	1.350	3.380	180	450	725	1000	1300	1550	1850	2125	2400	2700
35	365	1.125	0.994	2.490	250	625	1025	1400	1800	2150	2500	2850	3250	3600
55	603	0.875	0.601	1.500	450	1050	1700	2275	2900	3500	4100	4650	5200	6000
95	982	0.688	0.371	0.928	750	1750	2800	3700	4750	5900	6875	7700	8750	9700
145	151	0.563	0.249	0.623	1100	2600	4200	5550	7100	8500	10000	11500	12950	14400
180	181	0.500	0.196	0.490	1500	3200	5200	7100	9000	10800	12500	14500	16300	18000
240	201	0.438	0.150	0.375	1900	4400	6900	9100	11600	14000	15400	17800	19300	20000
240	241	0.438	0.150	0.375	1900	4400	6900	9100	11600	14000	16400	18800	21300	23700
330 **	326 **	0.375	0.110	0.275	3000	6000	9500	12600	16000	19100	22300	25600	29000	32300
460 **	454 **	0.313	0.077	0.193	4000	8800	13700	18000	22500	27000	31500	36500	41400	45800
740 **	652 **	0.250	0.049	0.123	8000	15000	23000	29700	37200	45000	52500	59200	66500	***

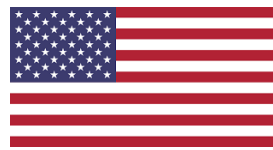

10 PUMPS SERIES

APPROXIMATE RATE OF DISCHARGE

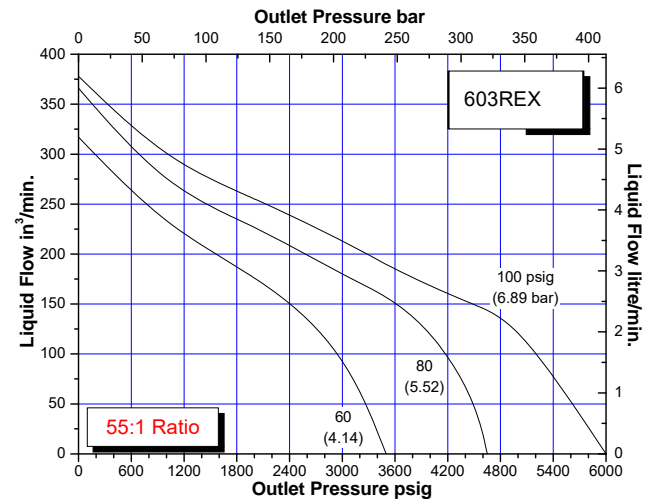
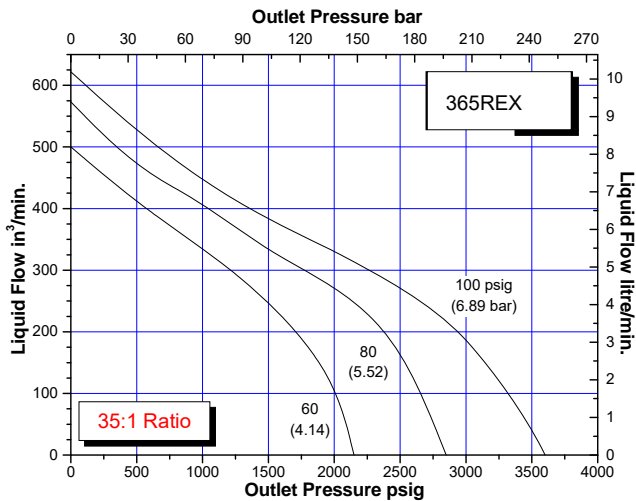
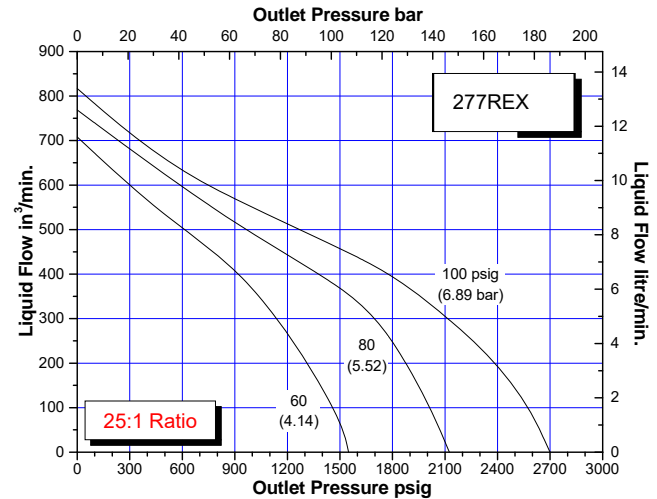
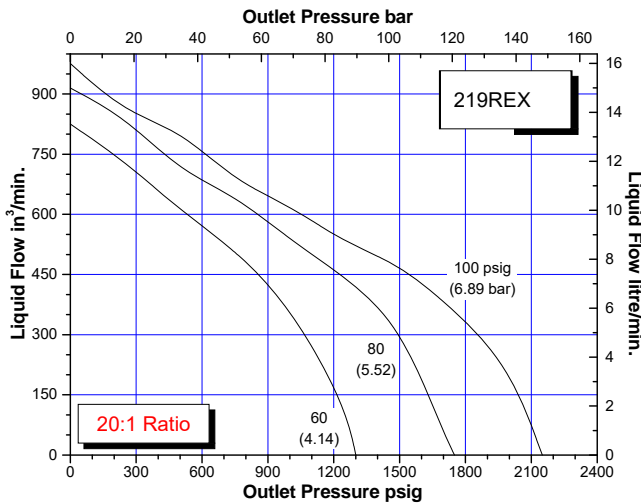
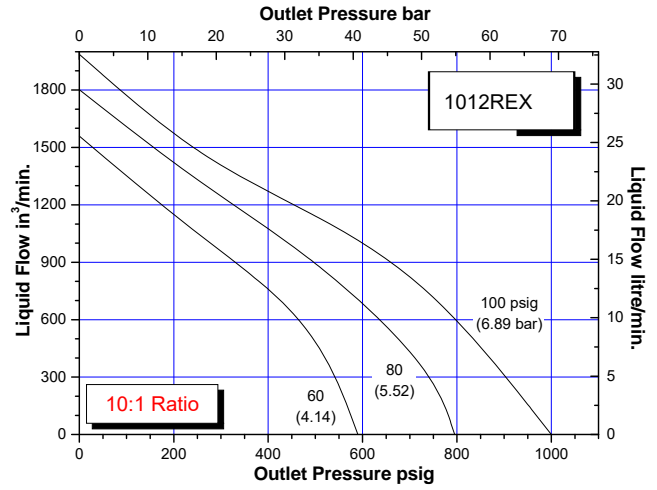
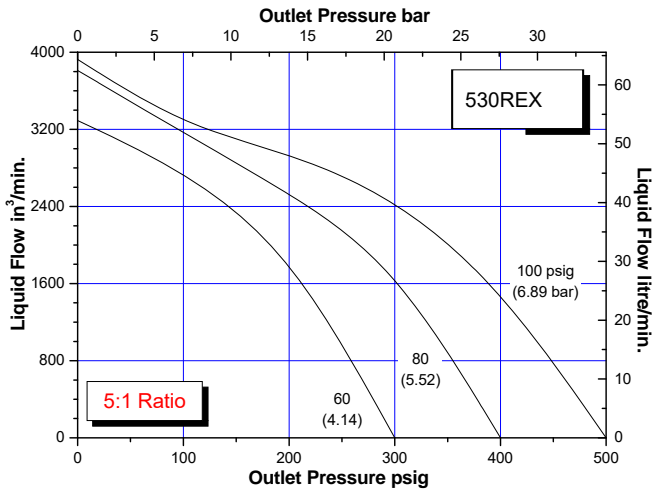

10 PUMPS SERIES

APPROXIMATE RATE OF DISCHARGE

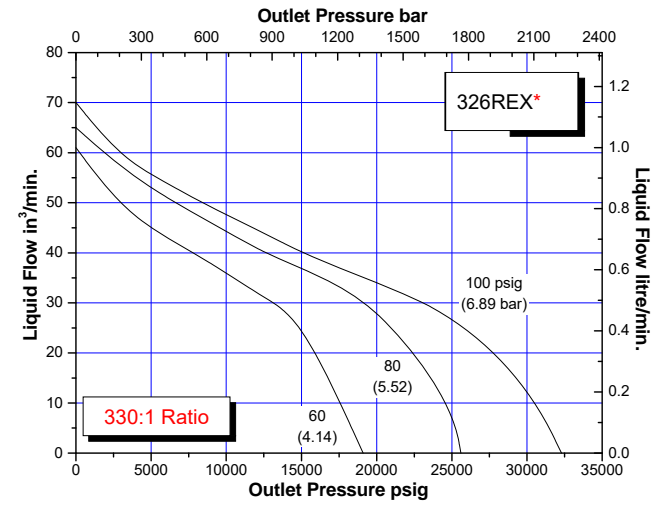
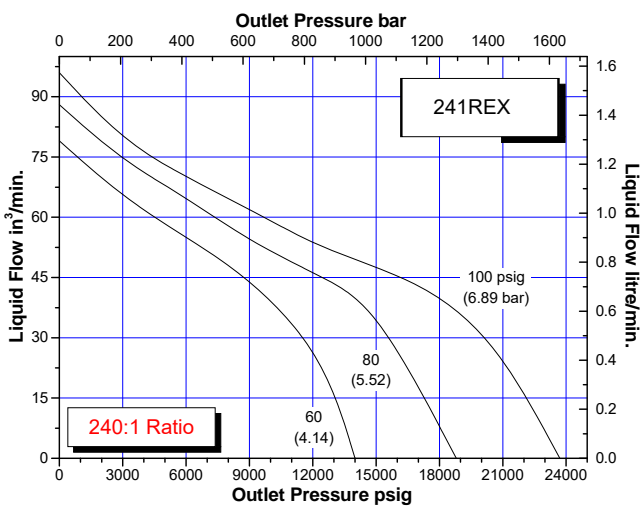
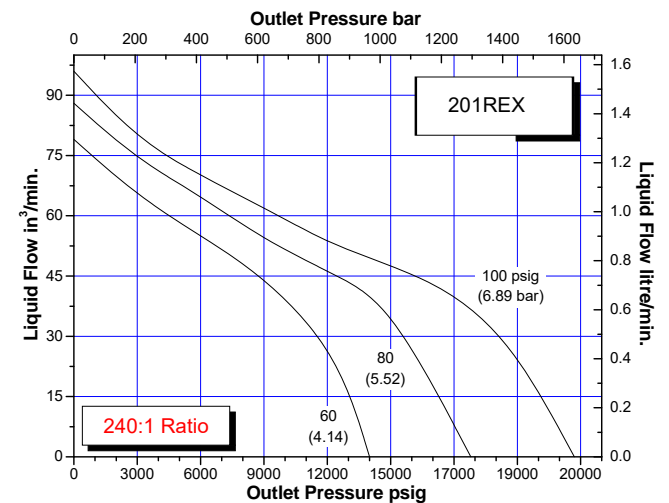
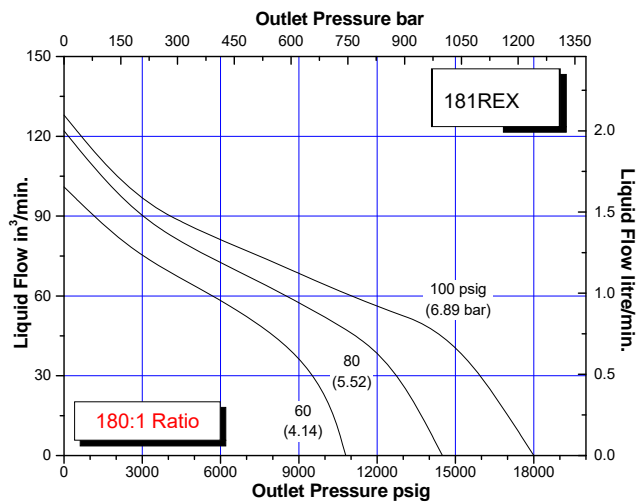
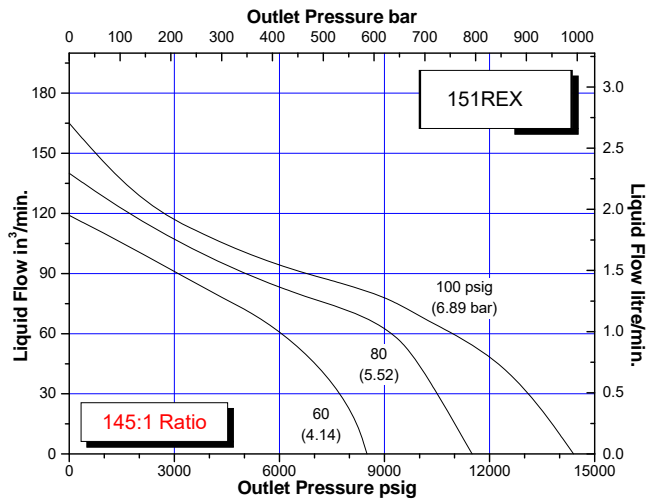
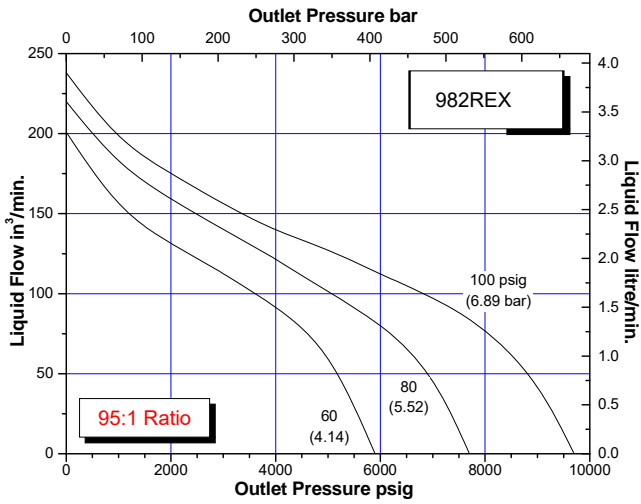

10 PUMPS SERIES

APPROXIMATE RATE OF DISCHARGE

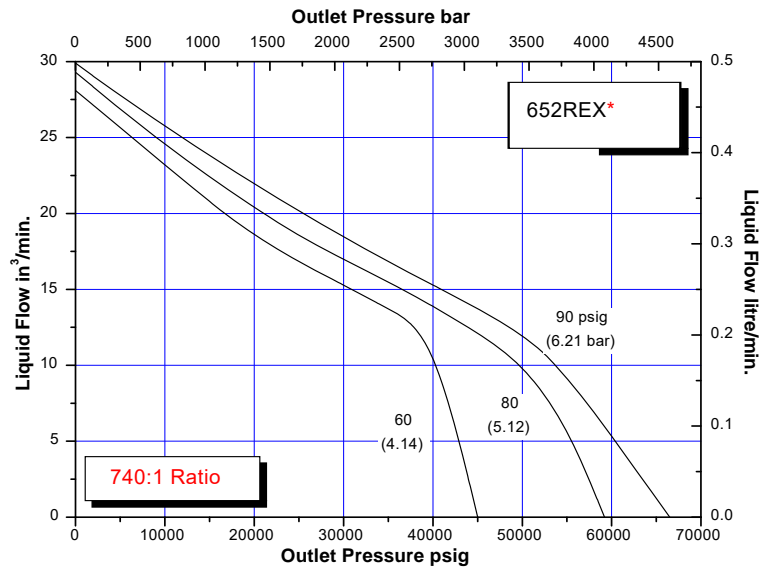
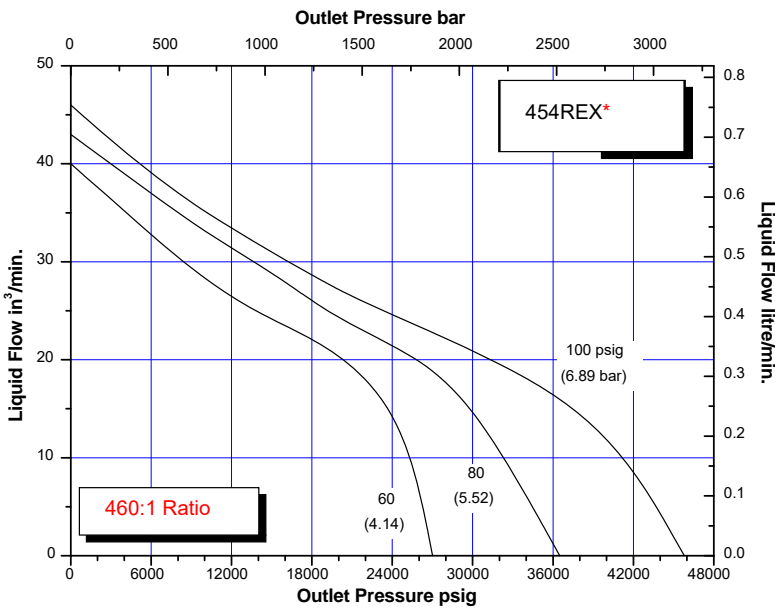

**High pressure systems
12000 Psi to 65000 Psi
Tubing cone and thread
Parker Autoclave / Spir Star**



Pumps Brands

SC Hydraulic - Most Common



SC Hydraulic Hig Flow



SC Hydraulic Gases Booster (Nitrogen)



Haskel Pumps -Liquid/Gases



Cat Pumps - Electrical Motor
Triplex Plunger



UDOR Pumps - Electrical
Triplex Plunger



Liquid Pump Cut-a-way

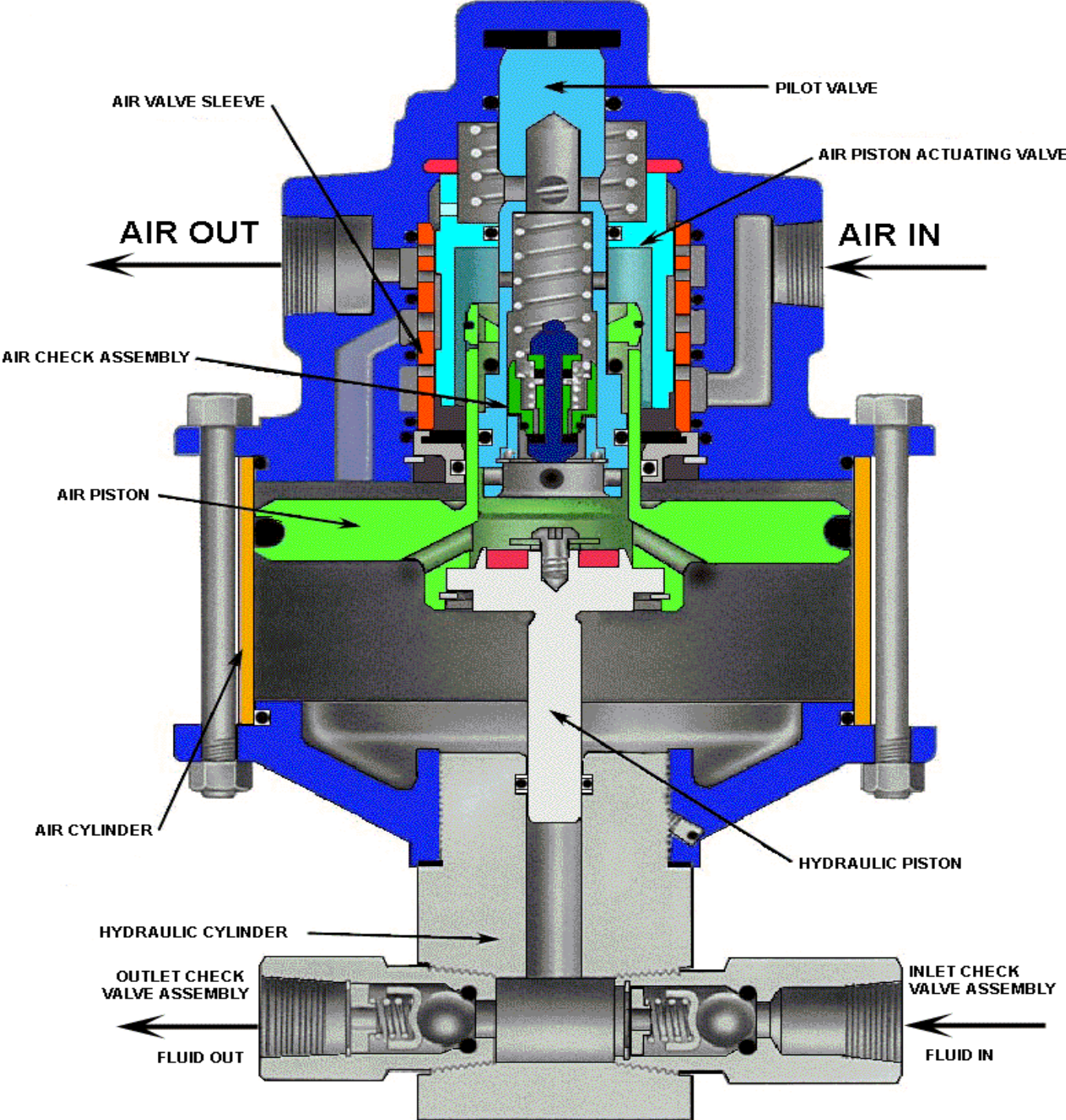

**HIGH PRESSURE SYSTEMS, HOSES, VALVES, GAUGES, PUMPS,
FITTINGS, ADAPTERS AND MORE**
BUY IT ONLINE STORE !

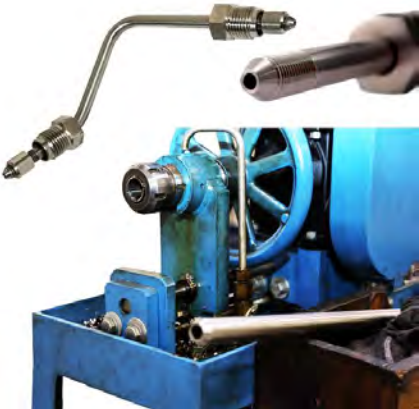

HIGH PRESSURE TUBE SERVICES

Bending, Cone & Tread your high pressure tubing lines needs. (hydro test bay, tubing kits, HPU's panels) Custom and build Your high pressure tubing system

